

Ecotype

COVERING SYSTEM
FOR ROLL-OFF CONTAINERS
AND TIPPER BODIES

USER MANUAL



Marcolin Covering s.r.l.

Via O. Michelin, 3
33170 Pordenone (Italia)
Tel +39 0434-570261

www.marcolincovering.it
info@marcolinsrl.it

Rev. 03

The translation, reprinting, digital storage or any other type of storage and diffusion, even in excerpts, of this manual and its content are strictly forbidden. Marcolin Covering s.r.l. reserves the right to make changes at any time without notice.

All mentioned product names and trademarks are exclusively owned by the respective holder.

Marcolin Covering s.r.l. took great care in editing this manual, however, the company denies responsibility for errors and omissions, if present, and for personal and animal injuries as well as for material and environmental damages as a consequence of the application of the manual's instructions.

This manual has been edited in accordance with the Machinery Directive 2006/42/CE.

SUMMARY

Summary	3
Chapter 1 Introduction and informations	5
1.1 Introduction	5
1.2 Explanatory convention.....	5
1.3 Information on the use of the machine.....	5
1.3.1 <i>Restrictions of use on the Control Box</i>	5
1.4 Product warranty	5
1.5 Declaration of Conformity and Manufacturer's CE Mark	5
1.5.1 <i>Facsimile of EC Declaration of Conformity</i>	6
1.5.2 <i>Facsimile of Manufacturer's CE Marking Plate</i>	7
1.6 Prohibition of putting into service	7
1.7 General Directions	7
1.8 The importance of the manual	8
1.8.1 <i>Adequateness</i>	8
1.8.2 <i>Conservation</i>	8
1.8.3 <i>Comprehension</i>	8
1.8.4 <i>Illustrations</i>	8
1.8.5 <i>If the Manual is Lost</i>	8
1.8.6 <i>Conveyance of notions, of the manual and information</i>	8
1.8.7 <i>How do I convey notions in the correct way?</i>	8
1.8.8 <i>How can I demonstrate that the notions have been conveyed?</i>	8
1.8.9 <i>Print-outs for conveyance of notions and of the manual</i>	9
Chapter 2 The Ecotype Covering System, dangerous situations	12
2.1 Covering System functions	12
2.2 Covering System movement.....	12
2.3 Covering System components	12
2.4 Danger zone, exposed person, operator; definitions	12
2.5 Situations of risk and danger for people's health	13
2.5.1 <i>Danger of slipping and falling</i>	13
2.5.2 <i>Danger of limb crushing and/or shearing injuries</i>	13
2.5.3 <i>Danger of crushing</i>	14
2.5.4 <i>Danger of crushing from the automatic rear closing system (optional)</i>	14
2.5.5 <i>Danger of snagging and consequent danger</i>	14
2.5.6 <i>Danger of detachment and covering's projection</i>	15
2.6 Environmental and operative situations that can damage the covering	15
2.6.1 <i>Danger of unloading material with the covering not completely folded on the front</i>	15
2.6.2 <i>Danger of bows bending</i>	15
2.6.3 <i>Danger of ice forming</i>	15
2.6.4 <i>Wind dangers</i>	16
2.7 What has not to be done with the covering	16
2.8 Residual risk	17
2.9 Safety services and documentation provided to the user.....	17
2.9.1 <i>Training course</i>	17
2.9.2 <i>User manual delivery</i>	17
2.9.3 <i>Safety signs and signals on the machine</i>	17
Chapter 3 Handling the system - operations	19
3.1 Hand-operated version	19
3.1.1 <i>Unfolding the Ecotype for covering the tipper body</i>	19
3.1.2 <i>Folding the Ecotype for uncovering the tipper body</i>	19
3.1.3 <i>In case of empty tipper body</i>	19
3.2 Electrically operated version	20
3.2.1 <i>Description of the Control Box</i>	20
3.2.2 <i>Emergency pushbutton key, safety shutdown</i>	20
3.2.3 <i>Control Box components that can be used by the operator</i>	20

3.2.4 Description of the remote control "TX MARCOLIN" system	21
3.2.5 Reprogramming the "TX MARCOLIN" radio remote control	21
3.2.6 Unfolding the Ecotype for covering the tipper body	22
3.2.7 Interruption of machine operations	22
3.2.8 How can I stop the machine in case of emergency?	22
3.2.9 Restoring of standard operative conditions	22
3.2.10 Machine stop in safety conditions	23
3.2.11 Folding the Ecotype for uncovering the tipper body	23
3.2.12 How do you interrupt the machine operations?	23
3.2.13 How do you stop the machine in case of emergency?	23
3.2.14 Machine stop in safety conditions	23
3.2.15 In case of empty tipper body	23
3.3 Using the accessory equipment (if installed)	23
3.3.1 Automatic rear closing device	23
3.4 What has to be done if the covering does not work electrically?	24
3.4.1 Check and replacement of the internal fuse in emergency case	24
Chapter 4 Maintenance work of the Ecotype Covering System	25
4.1 Introduction	25
4.2 Safety Norms	25
4.3 Instructions on washing the machine	25
4.4 Ordinary maintenance	26
4.4.1 General tightening up of the screw connections	26
4.4.2 Check the conservation status of metal structure and bows	26
4.4.3 Check the tarpaulin conservation status	26
4.4.4 Check the cables' tensioning and conservation status	26
4.4.5 Lubricate and grease	27
4.4.6 Check the elastic strings with hooks or the automatic lateral hooks (only if installed)	27
4.4.7 Replace broken or damaged fastening hooks on the outer board wall (only if installed)	27
4.4.8 Check the contact plates (only if installed)	28
4.4.9 Check the sliding paths of the covering	28
4.4.10 Check the pulleys	28
4.5 Ordinary maintenance that can be carried out exclusively by operators equipped with the installer's manual	29
4.5.1 Bow replacement	29
4.5.2 Tarpaulin replacement	30
4.5.3 Steel cables replacement	31
4.5.4 Repositioning the covering	36
4.6 Troubleshooting table for electrically operated covering system	37
4.7 Extraordinary maintenance work	39
4.8 Important information for the machine management	39
4.8.1 Machine disassembly and demolition	39
4.8.2 Machine noisiness	39
4.8.3 Vibrations	39
4.8.4 Modifying the machine	39
4.8.5 Transporting the covering	39
4.8.6 Check register, maintenance tables	39
Chapter 5 Machine check register	40
5.1 Introduction to the check register	40
5.2 Planned maintenance check register	40
5.2.1 List of operations	40
5.2.2 Register of the maintenance intervention carried out on the machine	40
5.3 Yearly extraordinary maintenance check register	42
5.3.1 Authorised workshops, retail outlets, spare parts, assistance and installation	42
5.3.2 List of operations to be carried out by the authorised workshop	42
5.3.3 Register of annual checks carried out	43
Chapter 6 Enclosures	44
6.1 Reference diagram for electrical connections	44
6.2 Print-outs for certifying the training course completion	45

Chapter 1 INTRODUCTION AND INFORMATIONS

1.1 Introduction

Load securing, for example of aggregates, during the freight transport on road is required by law.

Marcolin Covering s.r.l. has developed the Ecotype Covering System, which fulfils the legal obligation and satisfies practical and functional needs of its user.

This manual provides all the necessary instructions for a safe application and for keeping fully functional the Ecotype Covering System.

Thank you for having chosen the Ecotype Covering System of Marcolin Covering s.r.l.!

1.2 Explanatory convention

When equipped with the electric device with remote control "TX MARCOLIN", the covering changes to a "machine" being moved by a different energy than the human force. For exposition convenience, all along this manual the synonym "machine" refers to the Ecotype Covering System.

1.3 Information on the use of the machine

The machine was built for operating in environmental temperatures between $- 10^{\circ} \text{C}$ and $+ 40^{\circ} \text{C}$. For any other climatic condition, ask the manufacturer for instructions. The machine's operational function is confined to cover the tipper body to prevent material from falling out during road travel.

The covering equipped with electric driving system has to be powered up only when the vehicle is stationary.

1.3.1 Restrictions of use on the Control Box



WARNING!

It is absolutely forbidden to use the Control Box when the vehicle is moving.

The constructor declines any responsibility.

Any other use is defined as "**IMPROPER USE**". The machine's "lifecycle" depends on the frequency of its use and the preservation status in which it is maintained.

1.4 Product warranty

The covering is supplied according to the contractual warranty conditions stipulated at the time of purchase. The warranty consists in supplying and replacement of components that cannot be used because of an ascertained material's flaw and the repairing of those pieces that are defective: the examination of the defects and their causes it is exclusively carried out by the manufacturer.

The component's replacement is made by using exclusively original spare parts.

Any delays do not give the buyer the right to claim for damages, nor to extend the warranty. The warranty ceases if the machine is used in a manner not conform to these conditions or to the manufacturer's instructions and if parts are disassembled, repaired or replaced without the manufacturer's authorisation.

The manufacturer is exempt from all responsibility and obligation for any accident or damage to people, objects, animals and environment which could occur for or during the use of the vehicle supplied for installation, that is, also during testing and even if the accident was caused by a fault in building or materials.

1.5 Declaration of Conformity and Manufacturer's CE Mark

In compliance with the Machinery Directive 2006/42/EC, which, in Annexes IIA and III, contemplates the declaration of conformity and the CE marking of the machine, here follows the facsimiles of the EC Declaration of Conformity and the CE marking plate attached to the machine.

The Declaration of Conformity signed by the legal representative of the MARCOLIN COVERING s.r.l. is handed over conjointly with the machine.

1.5.1 Facsimile of EC Declaration of Conformity



MARCOLIN COVERING S.r.l.
www.marcolincovering.it

DICHIARAZIONE DI CONFORMITÀ
 ai sensi della Dir. 2006/42/CE, allegato II A.

DECLARATION OF CONFORMITY
 according to 2006/42/EC Dir., annex II A.

KONFORMITÄTSEKTLÄRUNG
 im Sinne der RL 2006/42/EG, Anhang II A.

DÉCLARATION DE CONFORMITÉ
 Conformément à la Dir. 2006/42/CE, annexe II A.



Il sottoscritto, rappresentante del costruttore
The undersigned, representing the manufacturer
 Der Unterzeichnende, Vertreter des Herstellers
Le soussigné, représentant du constructeur

MARCOLIN COVERING S.r.l., via Orefici Michelin, 3 - 33170 Pordenone (Italia),
 MARCOLIN COVERING S.r.l., via Orefici Michelin, 3 - 33170 Pordenone (Italy),
 MARCOLIN COVERING S.r.l., via Orefici Michelin, 3 - 33170 Pordenone (Italien),
 MARCOLIN COVERING S.r.l., via Orefici Michelin, 3 - 33170 Pordenone (Italie),

DICHIARA CHE / STATES THAT / ERKLÄRT, DASS / DÉCLARE QUE

la presente dichiarazione di conformità è rilasciata sotto la responsabilità esclusiva del fabbricante e si riferisce al seguente prodotto:
the Declaration of Conformity is issued under our sole responsibility and belongs to the following product:
 der Hersteller die alleinige Verantwortung für die Ausstellung dieser Konformitätserklärung trägt und sich auf das folgende Produkt bezieht:
la présente déclaration de conformité est établie sous la seule responsabilité du fabricant et se réfère au produit suivant :

KIT DI COPERTURA	COVERING SYSTEM	ABDECKSYSTEM	SYSTÈME DE BÂCHAGE
Prodotto:	Product:	Produkt:	Produit :
N. di Serie:	Serial No.:	Serien-Nr.:	N. de Série :
Anno di costruzione:	Year of Manufacture:	Baujahr:	Année de construction :

L'oggetto della dichiarazione di cui sopra è conforme alla pertinente normativa dell'Unione Europea:

- Direttiva Macchine 2006/42/CE (requisiti essenziali di sicurezza e salute), con riferimento alla pertinente norma armonizzata UNI EN ISO 12100:2010;
- Regolamento n°10 UN/ECE rev. 6 - Regolamento (CE) n°661/2009 - Regolamento (UE) n°1230/2012;
- Direttiva Apparecchiature Radio (RED) 2014/53/UE.

La messa in servizio della macchina e la definitiva conformità alla Direttiva Macchine sono assoggettate alle seguenti condizioni:

- montaggio eseguito a regola d'arte e nel rispetto di tutte le istruzioni contenute nel manuale dell'installatore fornito dalla MARCOLIN COVERING S.r.l.;
- emissione della dichiarazione di corretta installazione da parte dell'installatore (rif. Direttiva Macchine, Allegato I, 1.7.4.2., i));
- partecipazione dell'utente finale al corso di formazione e consegna del manuale dell'utente;

The object of the declaration described above is in conformity with the relevant legislation of European Union:

- 2006/42/EC Machinery Directive (safety and health essential requirements), with reference to the relevant harmonised standard EN ISO 12100:2010;
- UN/ECE Regulation 10 Rev. 6 - Regulation (EC) No. 661/2009 - Regulation (EU) No. 1230/2012;
- 2014/53/EU Radio Equipment Directive (RED).

The putting into service of the machinery and its final conformity with the Machinery Directive are subjected to following conditions:

- assembly carried out in a good and workmanlike manner, in conformity with all the instructions included in the installation manual supplied by MARCOLIN COVERING S.r.l.;
- issue of the declaration of correct installation by the installer (ref. Machinery Directive, annex I, 1.7.4.2., i));
- attendance of the training course by the final user and handing over of the user manual;

Der Gegenstand der oben angegebenen Erklärung entspricht der einschlägigen Rechtsvorschrift der Europäischen Gemeinschaft:

- Richtlinie 2006/42/EG (wesentliche Erfordernisse der Sicherheit und der Gesundheit) mit Bezug auf die einschlägige harmonisierte Norm EN ISO 12100:2010;
- UN/ECE Regelung Nr. 10 Änderungsreihe 6 - Verordnung (EG) Nr. 661/2009 - Verordnung (EU) Nr. 1230/2012;
- Funkanlagen-Richtlinie (RED) 2014/53/EU.

Die Inbetriebnahme der Maschine und deren endgültige Konformität mit der Maschinenrichtlinie sind folgenden Bedingungen unterworfen:

- einer ordnungsgemäß und fachgerecht durchgeführten Montage, die den in der von MARCOLIN COVERING S.r.l. mitgelieferten Montageanleitung enthaltenen Anweisungen entspricht;
- der Ausstellung der Erklärung einer korrekten Installation durch den Installateur (laut der Maschinenrichtlinie, Anhang I, 1.7.4.2., i));
- der Teilnahme des Endverbrauchers an einem Schulungskurs und der Übergabe der Betriebsanleitung;

L'objet de la déclaration décrite ci-dessus est conforme avec la législation pertinente de l'Union européenne :

- Directive Machines 2006/42/CE (conditions essentielles de sécurité et santé), selon la norme harmonisée EN ISO 12100 :2010 ;
- Règlement N° 10 Série 06 d'amendements au règlement - Règlement (CE) N° 661/2009 - Règlement (UE) N° 1230/2012 ;
- Directive équipements radio (RED) 2014/53/UE.

La mise en service de la machine et la conformité définitive à la Directive Machines sont assujetties aux conditions suivantes :

- Montage effectué selon les règles de l'art et dans le respect de toutes les instructions contenues dans le manuel de l'installateur fourni par la société MARCOLIN COVERING S.r.l. ;
- Émission de la déclaration de correcte installation par l'installateur (réf. Directive Machines, annexe I, 1.7.4.2., i));
- Participation de l'utilisateur final au cours de formation et la remise du manuel de l'utilisateur ;

e AUTORIZZA il sig.: / and AUTHORISES Mr.: / und ERMÄCHTIGT Herrn: / et AUTORISE M.:
Barbui Filippo, via Orefici Michelin, 3 - 33170 Pordenone (Italia)

a costituire e custodire il fascicolo tecnico per suo conto presso la sede della società MARCOLIN COVERING S.r.l.
to compile and to store the technical file on its behalf at the Company site of MARCOLIN COVERING S.r.l.
 die technische Unterlage in seinem Namen im Firmensitz von MARCOLIN COVERING S.r.l. anzulegen und aufzubewahren.
à constituer et garder le dossier technique en son nom chez le siège de la société MARCOLIN COVERING S.r.l.

Pordenone,

MARCOLIN COVERING S.r.l.

Il legale rappresentante / The legal representative / Der gesetzliche Vertreter / Le représentant légal

M-DIC01-04

1.5.2 Facsimile of Manufacturer's CE Marking Plate

As provided by the Machinery Directive 2006/42/EC, the machine displays in a visible, legible and indelible way an affixed plate with the following data:

- Name and address of the manufacturer.
- CE Marking (according to the Machinery Directive, annex III).
- Label of the machine's type and serial number.
- Year of manufacturing.



1.6 Prohibition of putting into service

The machine cannot be put into service after being subjected to constructive modifications or component's additions not concerning the planned or extraordinary maintenance, if not declared in conformity with the 2006/42/EC Machinery Directive and the other applicable EC directives.



WARNING!

IT IS ABSOLUTELY FORBIDDEN TO MODIFY THE MACHINE!

Whoever modifies the machine becomes its manufacturer and assumes all civil and criminal liabilities provided for by law in force.

Whoever modifies the machine assumes the legal obligation of issuing a new CE Marking, new installation manual and user manual for the end user and an own EC Declaration of Conformity.



The replacement of whatever is usually called spare part is not considered as a modification.

1.7 General Directions



WARNING!

It is forbidden for personnel unable to absorb and understand the contents of this manual to operate the machine.

- Before working with the machine, operators, maintenance personnel and those authorised to use it are required to know the contents of this manual.
- The owner of the machine is committed to personally check that people in charge are adequately trained.
- The owner of the machine is committed to make sure that the above instructions are applied.
- Personnel in charge of operating and maintaining the machine must be equipped with clothing that is suited to the operations that need to be carried out.
- Personnel are committed to observing any warning, danger and obligation signs on the machine.
- Personnel must reflect physical and moral qualities such to gain the employer's full trust for taking the responsibility of using the machine and must not partake of drugs, alcohol or medicine which could cause drowsiness, slow reflexes or loss of balance.
- The machine must only be used for the operations for which it was designed and built for. The manufacturer declines all responsibility for any different use than what described in this manual, both during the warranty than afterwards.
- Personnel must not tamper with protections and safety devices.
- For the machine to work at its best and for the longest time, the user must make sure that maintenance is carried out at the intervals shown in the specific sections of this manual and record the maintenance done in the respective tables of the check register. If the machine works in extreme conditions or is subjected to work overloads, intervals between maintenance must be reduced.
- Adjustments and repairs must only be carried out by qualified personnel.

1.8 The importance of the manual

1.8.1 Adequateness

The manufacturer always tend to improve the product; it is therefore possible that a component in your machine may be changed in future machines. This does not lead to your machine's operating system to become inadequate; you may ask for adaptation to the manufacturer only in case of inconsistency. In all other cases, the manufacturer is not obliged to update plants or manuals.

At the precise historical-technical moment of the machine's construction, the installed operating and safety systems, the CE Certification and Marking ensure the respect of the directions of the MACHINE DIRECTIVE.

1.8.2 Conservation

The manual is to be preserved in a protected dry area, away from atmospheric agents (water, sun) or worse, fire. The manual is an integral part of the machine; it must be easily found for immediate consultation when necessary.

1.8.3 Comprehension

In case of doubt or difficulty in interpreting the subject matter of this manual, *the machine does not have to be used*; ask for an explanation on the matter and, when still in doubt, attend a brief training course at the manufacturer's premises.

1.8.4 Illustrations

Some of the illustrations in this publication may show components or accessories that are different from those assembled on your machine: this is due to the product's continuous improvement. In the illustrations, protections and covers may be removed to help clarify communication. *The MANUFACTURER reserves the right to carry out changes to the machine and the contents of this manual without prior notice.*

1.8.5 If the Manual is Lost

Given its importance to operational safety, in our opinion the manual should be kept constantly inside the machine. If the manual is lost, the operator is obliged to notify the safety manager immediately, who will then request a copy from the manufacturer.

1.8.6 Conveyance of notions, of the manual and information

We would like to inform the user that one of the main causes of accidents at work is the lack of information on the machine that the new operator is about to run. This manual must always be with the covering and its contents must be illustrated when the operator changes and when the vehicle onto which the covering is installed is sold.

1.8.7 How do I convey notions in the correct way?

For a proper transfer of notions:

- Instruct the new operator (or the new owner, in the case of sale) on all aspects concerning operations;
- Specifically highlight the components relative to operational safety;
- Carefully notify them the machine's dangers;
- Hand the manual over to the new operator (or new owner), highlighting the contents in detail;
- In the event of yield to the new owner, also hand over the Manufacturer's Declaration of Conformity and highlight the presence of the plate with the marking;
- Make sure that the new operator (or owner) has completely understood the instructions and that there are no doubts on how the machine works.

1.8.8 How can I demonstrate that the notions have been conveyed?

Considering the great importance of assuming adequate knowledge of the machine and that the operator is no longer responsible for it in the instant that they cease to operate it, we considered worthwhile to insert some forms drawn up in a suitable manner and aimed at witnessing the occurrence of and correct withdrawal of the machine at the manufacturer's premise (**declaration of responsibility**) and of the conveyance carried out between operators and owners (**declaration of training course completion – see paragraph 6.2**).

1.8.9 Print-outs for conveyance of notions and of the manual.

**DECLARATION OF ASSUMPTION OF RESPONSIBILITY
WHEN WITHDRAWING THE MACHINE**

The undersigned Mr.:

resident in: postcode:

address: no.:

phone / mobile: fax / e-mail:

AS:

- OWNER OF THE VEHICLE
- OPERATOR APPOINTED BY THE OWNER OF THE VEHICLE
- DEALER (OR SALESMAN)
- FINANCIAL DELEGATE
-

DECLARES, UNDER ITS OWN RESPONSIBILITY:

- to have received and understood the instructions for starting, operating, stopping and keeping in perfect conditions the machine;
- to have received the user manual and to commit himself to understand its contents before using the machine for the first time;

by the manufacturer of the Covering System mod.:

Ecotype

company **Marcolin Covering s.r.l.**

**COMMITTS HIMSELF ALSO TO THE CONVEYING OF NOTIONS
AND TO THE DELIVERING OF THE MANUAL TO THEIR SUCCESSOR OR NEW OWNER.**

SIGNATURE
MARCOLIN COVERING S.r.l.
Il legale rappresentante



SIGNATURE
Withdrawer

.....

Date:

CONVEYANCE OF NOTIONS AND OF THE MANUAL AMONG OPERATORS

The undersigned Mr.:

resident in: postcode:

address: no.:

phone / mobile: fax / e-mail:

DECLARES, UNDER HIS OWN RESPONSIBILITY:

- to have received and understood the instructions for operating and keeping in perfect conditions the machine;
- to have taken delivery of the manual and to commit to absorbing its contents before using the machine for the first time;

by Mr.:

resident in: postcode:

address: no.:

phone / mobile: fax / e-mail:

**COMMITTS HIMSELF ALSO TO THE CONVEYING OF NOTIONS
AND TO THE DELIVERING OF THE MANUAL TO THEIR SUCCESSOR OR NEW OWNER.**

SIGNATURE
PREVIOUS OPERATOR

SIGNATURE
NEW OPERATOR

.....

Date:

CONVEYANCE OF NOTIONS AND OF THE MANUAL AMONG OPERATORS

The undersigned Mr.:

resident in: postcode:

address: no.:

phone / mobile: fax / e-mail:

DECLARES, UNDER HIS OWN RESPONSIBILITY:

- to have received and understood the instructions for operating and keeping in perfect conditions the machine;
- to have taken delivery of the manual and to commit to absorbing its contents before using the machine for the first time;

by Mr.:

resident in: postcode:

address: no.:

phone / mobile: fax / e-mail:

**COMMITTS HIMSELF ALSO TO THE CONVEYING OF NOTIONS
AND TO THE DELIVERING OF THE MANUAL TO THEIR SUCCESSOR OR NEW OWNER.**

SIGNATURE
PREVIOUS OPERATOR

SIGNATURE
NEW OPERATOR

.....

Date:

CONVEYANCE OF NOTIONS AND OF THE MANUAL AMONG OPERATORS

The undersigned Mr.:
resident in: postcode:
address: no.:
phone / mobile: fax / e-mail:

DECLARES, UNDER HIS OWN RESPONSIBILITY:

- to have received and understood the instructions for operating and keeping in perfect conditions the machine;
- to have taken delivery of the manual and to commit to absorbing its contents before using the machine for the first time;

by Mr.:
resident in: postcode:
address: no.:
phone / mobile: fax / e-mail:

**COMMITTS HIMSELF ALSO TO THE CONVEYING OF NOTIONS
AND TO THE DELIVERING OF THE MANUAL TO THEIR SUCCESSOR OR NEW OWNER.**

SIGNATURE
PREVIOUS OPERATOR

SIGNATURE
NEW OPERATOR

.....

Date:

CONVEYANCE OF NOTIONS AND OF THE MANUAL AMONG OPERATORS

The undersigned Mr.:
resident in: postcode:
address: no.:
phone / mobile: fax / e-mail:

DECLARES, UNDER HIS OWN RESPONSIBILITY:

- to have received and understood the instructions for operating and keeping in perfect conditions the machine;
- to have taken delivery of the manual and to commit to absorbing its contents before using the machine for the first time;

by Mr.:
resident in: postcode:
address: no.:
phone / mobile: fax / e-mail:

**COMMITTS HIMSELF ALSO TO THE CONVEYING OF NOTIONS
AND TO THE DELIVERING OF THE MANUAL TO THEIR SUCCESSOR OR NEW OWNER.**

SIGNATURE
PREVIOUS OPERATOR

SIGNATURE
NEW OPERATOR

.....

Date:

Chapter 2 THE ECOTYPE COVERING SYSTEM, DANGEROUS SITUATIONS

2.1 Covering System functions

As mentioned in the introduction of this manual, the machine was built to allow loads to be covered in the sector of transporting inert materials.

2.2 Covering System movement

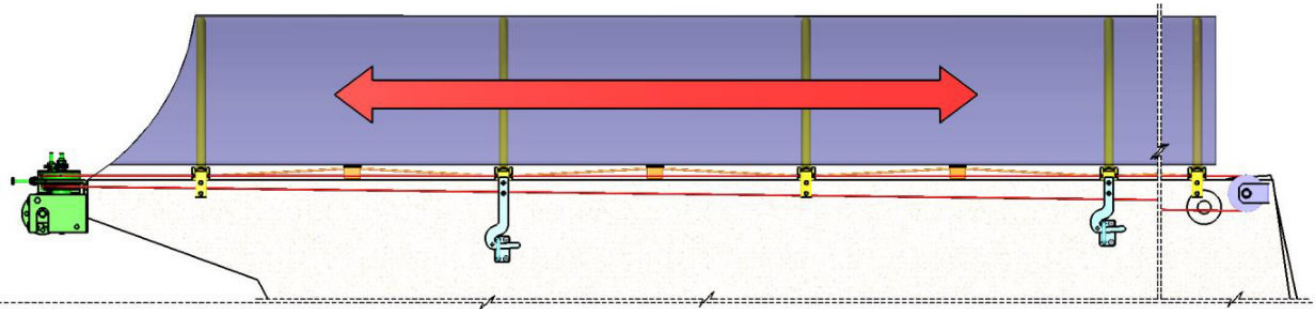

The covering carries out a horizontal movement which covers or uncovers, as required, the effective span of the tip up tipper body or roll-off container onto which it is installed.

2.3 Covering System components

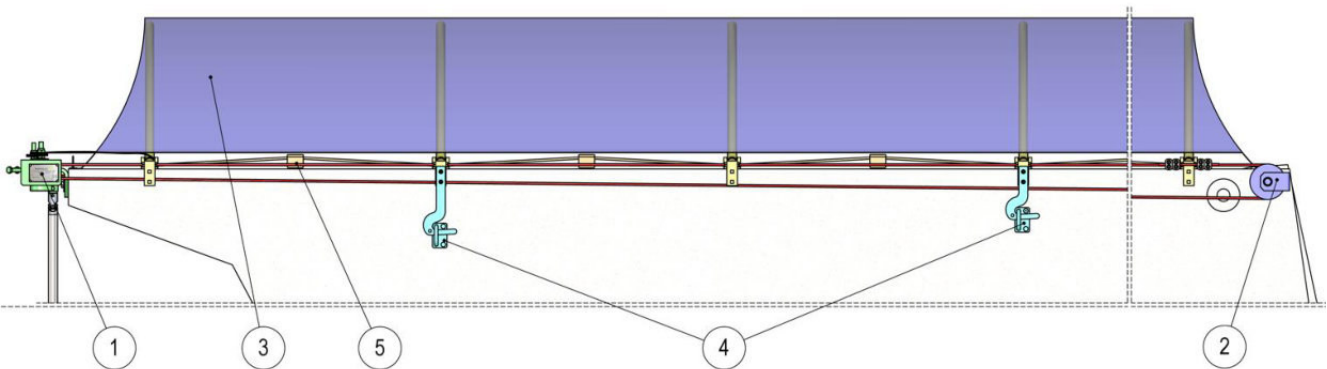

1. Front covering handling system (hand or electrically operated), with cable tensioning system;
2. Pulley and bracket for the return of the cable at the rear
3. Tarpaulin of variable size according to tipper body length;
4. Covering fastening system (depending on the model, could be supplied with a hermetic closure with rubber straps).
5. Folding and lifting system of the tarpaulin.

2.4 Danger zone, exposed person, operator; definitions

Before describing the machine operation, we believe it is useful to talk about some concepts usually stated on this manual; in such a way, the comprehension of the reasons for some prescriptions will be easier and actions will be done consciously, taking into account the responsibility involved in the machine operation.

i Definitions as stated on the Machinery Directive

Danger Zone

...means any zone within and/or around machinery in which a person is subject to a risk to his health or safety;

Exposed Person

...means any person wholly or partially in a danger zone;

Operator

...means the person or persons installing, operating, adjusting, maintaining, cleaning, repairing or moving machinery;

2.5 Situations of risk and danger for people's health

2.5.1 Danger of slipping and falling

The upper part of the covering is made up of a tarpaulin which, although tough, is only applied for "covering" the load. The lower part of the covering looks like a "hump".



WARNING!**SLIP AND FALL HAZARD!**

It is absolutely forbidden to walk or stand on the covering.
Use only EC-type approval ladders to access the top of the covering.

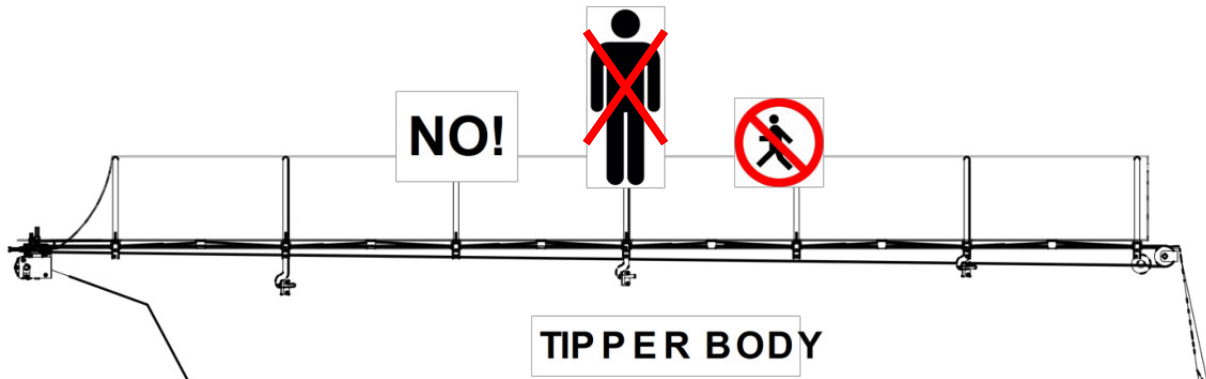

2.5.2 Danger of limb crushing and/or shearing injuries

Putting fingers between the running cables of the covering, inside the tensioning systems or into any gaps in the covering mechanism causes limbs to be crushed and/or sheared.



WARNING!**DANGER OF CRUSHING AND/OR SHEARING!**

It is absolutely forbidden to put any body part (particularly fingers) into any gaps or joints of the covering mechanism while it is operating

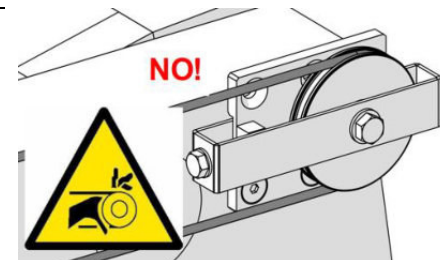

If an intervention to solve small problems is needed, proceed as follows:

- Stop the machine;
- Prevent unauthorised people from accidentally or voluntarily turning on the machine while you are solving the problem;
- Wear Personal Protective Equipment as provided by law in force on work related injury.

2.5.3 Danger of crushing

It is expressly forbidden to enter or stand inside the tipper body while the covering is in the phase of closing.

A situation of risk could occur during covering maintenance or repair or while cleaning inside the tipper body.

Moreover, it is possible that the covering hits the person's body, ex-posing it to serious risk of crushing

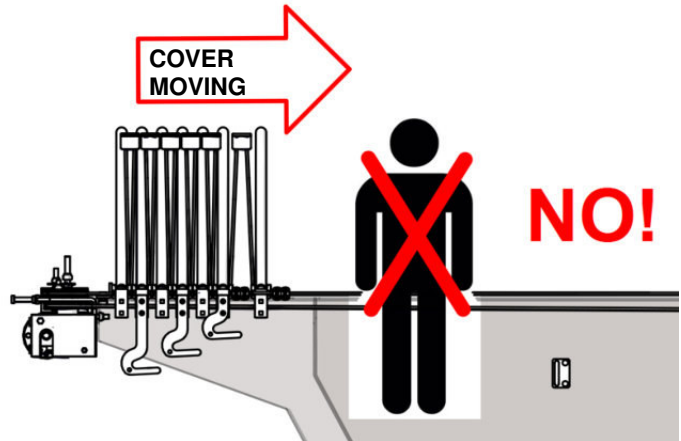

WARNING!

DANGER OF CRUSHING!

It is expressly forbidden to stand inside the tipper body in the presence of personnel who could start the machine.

2.5.4 Danger of crushing from the automatic rear closing system (optional)

The covering can be equipped with an innovative rear closing system which avoids the operator closing the end of the tarpaulin by hand.

This system requires particular surveillance by the operator; in fact, it is essential that, before closing it, the operator verifies that there is nobody behind the tipper body in the area where the covering and the tipper side meet

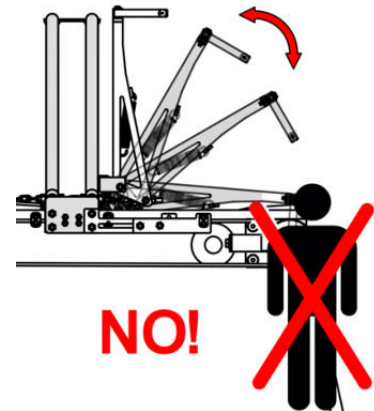

WARNING!

DANGER OF CRUSHING!

It is expressly forbidden to stand aside the tipper body in the area where the covering and the side meet.

2.5.5 Danger of snagging and consequent danger

When the tarpaulin is closed by using elastic strings, the operator's specific task is to position all the tarpaulin elastic strings which have been installed on the machine.

It only takes one flapping elastic to "hook" a person (bicycle, motorcycle etc), creating a situation of danger to health.



WARNING!

DANGER OF SNAGGING!

It is expressly forbidden to drive on road when the tensioning and locking tarpaulin elastics have not been correctly fastened.

2.5.6 Danger of detachment and covering's projection

Note:

The covering system is installed by trained and qualified personnel, in strict compliance with all the prescriptions and instructions of the installation manual. Before installing, the tipper body is scrupulously checked for the linearity and integrity of all the upper edge and the absence of any projecting element or any sharp edge all along the upper board.

Some operating conditions, such as:

- improper loading of heavy material (e.g. falling objects over a height of 1 meter);
- mishandling of the transport vehicle, causing a deflective impact to the sides of the tipper body.
- transport of hot material (e.g. bitumen);

can cause structural deflections to the tipper body side. These deflections could prevent the covering system from sliding.

If the operator finds the non-opening and/or closing of the covering system, due to a structural deflection of the tipper body side, **MUST NOT** drive the vehicle on road, because the deflections could stress the covering system and damage it irreversibly.

The additional stresses caused by a running vehicle on a damaged or malfunctioning covering system, may also cause the disruption and projection of the covering to the road.



WARNING!

DANGER OF DETACHMENT AND PROJECTION OF THE COVERING!

It is expressly forbidden to drive the vehicle on road when a structural deformation prevents the covering system from properly opening or closing.

2.6 Environmental and operative situations that can damage the covering

2.6.1 Danger of unloading material with the covering not completely folded on the front



WARNING!

DANGER OF DAMAGE TO THE COVERING COMPONENTS!

It is expressly forbidden to unload material if the covering has not been completely folded on the front.

2.6.2 Danger of bows bending



WARNING!

DANGER OF STAGNATION OF WATER OR SNOW IN THE TARPAULIN THAT WILL LEAD TO THE BOWS BENDING!

In the event of rain or snow, make sure that the covering is well unfolded



WARNING!

DANGER OF OVERLOADING THE COVERING THAT WILL LEAD TO THE BOWS BENDING!

Don't let the snow accumulate on the covering.

2.6.3 Danger of ice forming



WARNING!

DANGER OF BLOCKING THE COVERING MOVEMENT SYSTEM!

In the event of temperatures reaching below 0° C, remove the ice between the sliding parts and the edge of the tipper body.

2.6.4 Wind dangers



WARNING!

IT IS EXPRESSLY FORBIDDEN TO OPERATE WITH WINDS WITH A FORCE UPPER THAN THE 6TH DEGREE OF THE BEAUFORT SCALE, which condition is determined by:
large branches in motion, whistling heard in overhead wires, umbrella use becomes difficult.
The manufacturer denies any responsibility.

BEAUFORT SCALE

Description	nr.	Conditions	km/h
HURRICANE FORCE	12	Severe widespread damage to vegetation and structures. Debris and unsecured objects are hurled about.	over 117.4
VIOLENT STORM	11	Widespread vegetation and structural damage likely.	102.2 ~ 117.4
STORM, WHOLE GALE	10	Trees are broken off or uprooted, structural damage likely.	87.8 ~ 102.2
STRONG/SEVERE GALE	9	Some branches break off trees, and some small trees blow over. Construction/temporary signs and barricades blow over.	74.5 ~ 87.8
GALE, FRESH GALE	8	Some twigs broken from trees. Cars veer on road. Progress on foot is seriously impeded.	61.6 ~ 74.5
HIGH WIND, MODERATE GALE, NEAR GALE	7	Whole trees in motion. Effort needed to walk against the wind.	49.7 ~ 61.6
STRONG BREEZE	6	Large branches in motion. Whistling heard in overhead wires. Umbrella use becomes difficult. Empty plastic bins tip over.	38.5 ~ 49.7
FRESH BREEZE	5	Branches of a moderate size move. Small trees in leaf begin to sway.	28.4 ~ 38.5
MODERATE BREEZE	4	Dust and loose paper raised. Small branches begin to move.	19.4 ~ 28.4
GENTLE BREEZE	3	Leaves and small twigs constantly moving, light flags extended.	11.9 ~ 19.4
LIGHT BREEZE	2	Wind felt on exposed skin. Leaves rustle. Wind vanes begin to move.	5.4 ~ 11.9
LIGHT AIR	1	Smoke drift indicates wind direction. Leaves and wind vanes are stationary.	0.7 ~ 5.4
CALM	0	Smoke rises vertically.	0 ~ 0.7

2.7 What has not to be done with the covering

The only purpose of the covering is to "cover the load" during road travel; it must absolutely not be used to level the load. Levelling the load using the covering constitutes improper use of the machine and the manufacturer denies any responsibility. In the event of this kind of use, the contractual warranty expires.

The covering equipped with electric driving system has to be powered up only when the vehicle is stationary.



CAUTION!

RISK OF DAMAGING THE COVERING COMPONENTS!

It is expressly forbidden to level the material with the covering. Expiry of warranty.



WARNING!

DANGER OF DAMAGE TO THE COMPONENTS OF THE COVERING!

To prevent damaging the covering, do not attempt to unload the materials if the covering is not fully open.



WARNING!

Do not power the Control Box with power supplies other than vehicle batteries or with systems that have not been authorized by Marcolin Covering.



WARNING!

It is absolutely forbidden to use the Control Box when the vehicle is moving.
The constructor declines any responsibility.

2.8 Residual risk

As for all machines, for the Ecotype covering it is impossible, during design, to eliminate all the risks connected to proper and improper use; consequently, it is also impossible for the manufacturer to foresee all the safety systems.

The proper use of the machine by the operators who run it alternately at different times, remains, in any case, the most important factor to guarantee safety.

Perfect knowledge of injury prevention norms, methodical use of personal protective equipment and a good dose of common sense, contribute to preserving the machine in a good state and avoiding accidents or dangerous situations.

Despite all this, conditions may occur which we will call "**RESIDUAL RISK**", which could be caused by:

- Non-observance of the directions given in this manual for which the manufacturer is exempt from all responsibility.
- Any type or kind of incalculable factors for which the manufacturer is exempt from any responsibility.

2.9 Safety services and documentation provided to the user

2.9.1 Training course

After the covering systems' installation on the vehicle and delivery to the final user, Marcolin Covering s.r.l. (or authorised retailer/installer) gives the owner (or delegated operator) a training and apprehension course on all the necessary procedures to start, conduct, stop and maintain the machine in efficiency.

During the training, safety and operative prescriptions for the health of the operator and the other workers are also given.

The documentation on the implementation and certification of the training courses can be found in annex 6.2.

2.9.2 User manual delivery

This manual is mandatorily issued with each covering system and it is delivered to the final user from the authorised installer of the covering system.

2.9.3 Safety signs and signals on the machine

The manufacturer applies some easy to read and intuitive plates and pictograms on the machine for informing about possible dangerous situations.



WARNING!
ALL SAFETY SIGNS MUST NOT BE REMOVED
IMPORTANT INFORMATION!

The presence of the safety signs **DOES NOT** exempt the operator from the training course or from the perfect knowledge of the present manual.

Even if the plates are of a high quality, they can be damaged or become unreadable over the time. **AT THE FIRST SIGN OF DETERIORATION, REQUEST THE ORIGINAL SPARE PART TO MARCOLIN COVERING SRL OR TO THE RETAILERS.**

It is forbidden to use the machine if the safety signs are worn, illegible or removed.

 <p>IT Non movimentare la copertura e non mettersi alla guida in presenza di raffiche di vento superiori al 6° grado della scala di Beaufort! EN It is forbidden to operate the covering system and to drive the vehicle with winds with a force upper than the 6th degree of the Beaufort scale! DE Bei einer Windgeschwindigkeit höher als Windstärke 6 laut Beaufortskala ist es verboten das Abdecksystem zu bedienen und mit dem Fahrzeug zu fahren! FR Il est interdit d'actionner le système de bâchage et de rouler avec le véhicule en présence de rafales de vent supérieures au 6ème degré de l'échelle de Beaufort</p>	 <p>IT Non usare acqua ad alta pressione per lavare il motore e la centralina della copertura elettrica! EN Do not use high pressure water for cleaning the engine and the control unit of the electric covering system! DE Benützen sie niemals Hochdruckwasser zum Reinigen des Motors und der Steuereinheit des elektrischen Abdecksystems! FR Ne pas utiliser eau à haute pression pour nettoyer le moteur et le boîtier de commande du système de bâchage électrique !</p>
 <p>IT Non movimentare la copertura durante gli interventi di manutenzione! EN Do not operate the covering system during its maintenance operations! DE Bedienen Sie niemals das Abdecksystem während den Wartungseingriffen! FR Ne pas actionner le bâchage pendant son entretien !</p>	 <p>IT Non utilizzare la copertura quando il veicolo è in movimento. EN It is forbidden to use the covering system when the vehicle is moving. DE Es ist verboten, das Abdecksystem zu bedienen, wenn das Fahrzeug sich in Bewegung befindet. FR Il est absolument interdit d'actionner le bâchage quand le véhicule est en marche.</p>
 <p>IT Non scaricare il materiale se la copertura non è stata completamente aperta, pericolo di danni ai componenti! EN It is forbidden to unload material, if the covering system has not been completely folded together, danger of damage to the components! DE Es ist verboten bei nicht vollständig geöffneter (eingefahren) Abdeckplane die Entladung des Ladeguts durchzuführen. Die Bauteile des Abdecksystems könnten beschädigt werden! FR Il est interdit de procéder avec le déchargement du matériel si le bâchage n'est pas complètement replié. Danger de dommages au composants du bâchage!</p>	 <p>IT Prima di movimentare la copertura e/o mettersi in marcia su strada, pulire il telo dalla neve, ghiaccio o qualsiasi altro imbrattamento. EN Before moving the cover and/or driving on the road, clean the tarpaulin from snow, ice or any other contamination. DE Vor dem Öffnen oder Schließen des Abdecksystems ist die Plane von Schnee, Eis oder sonstigen Verunreinigungen zu säubern. FR Avant de déplacer le bâchage et/ou se mettre en marche, nettoyer la bâche de la neige, la glace ou toute autre contamination.</p>
 <p>IT Non chiudere la copertura, quando il carico supera il livello dell'arco. Il telo non è adatto a livellare il carico! EN Do not use the tarpaulin to level the load when it exceeds the bow level. The tarpaulin is not suitable for levelling the load! DE Benützen Sie nicht die Abdeckplane zum Ebenen des Ladeguts. FR Ne pas utiliser la bâche pour niveler la charge lorsqu'elle dépasse le niveau de l'arceau. Le bâchage ne convient pas pour niveler la charge !</p>	 <p>IT Osservare le ulteriori prescrizioni di sicurezza e gli interventi di manutenzione ordinaria e straordinaria riportate nel manuale dell'utente del produttore. EN Observe all further safety precautions and carry out the ordinary and extraordinary maintenance as described in the manufacturer's user manual. DE Bitte beachten Sie die weiteren Sicherheitshinweise in der Betriebsanleitung des Herstellers sowie die dort enthaltenen Vorgaben für die ordentlichen und außerordentlichen Wartungsarbeiten. FR Suivez les instructions supplémentaires de sécurité et effectuez les interventions d'entretien ordinaire et extraordinaire contenues dans le manuel de l'utilisateur du fabricant.</p>
 <p>IT Non sostare o camminare sulla copertura, pericolo di caduta! EN It is forbidden to stand or walk over the covering, danger of falling! DE Es ist verboten, auf der Abdeckplane zu stehen oder zu gehen. Sturzgefahr! FR Il est interdit de stationner ou marcher sur le bâchage, danger de chute !</p>	

www.marcolincovering.it

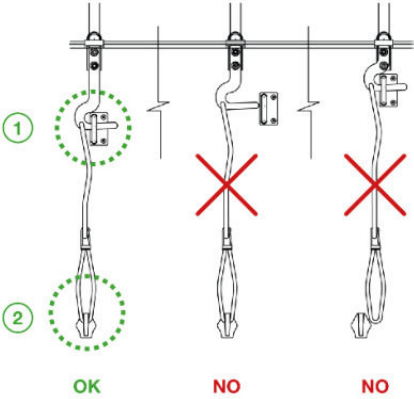

IT Prima di mettersi alla guida, assicurarsi che gli agganci automatici per fissare il telo alla vasca siano nella corretta posizione (1) e le corde con gli elastici agganciati agli appositi ganci (2). **È assolutamente vietato mettersi alla guida senza essersi assicurati che tutti i dispositivi di sicurezza siano correttamente posizionati.**

EN Before driving, make sure that the automatic hooks for securing the tarp to the body are in the correct position (1) and the elastic ropes are hooked to the proper hooks (2). **It is strictly forbidden to start driving before you make sure that all safety devices are correctly positioned.**

DE Bevor Sie fahren, vergewissern Sie sich, dass sich die automatischen Haken für die Befestigung der Plane an der Mulde in der korrekten Lage befinden (1) und dass die Gummispannbänder an die vorgesehenen Haken eingehakt sind (2). **Es ist streng verboten die Fahrt zu beginnen, ohne sich vergewissert zu haben, dass alle Sicherheitsvorrichtungen korrekt eingestellt sind.**

FR Avant de commencer à rouler, il faut s'assurer que les crochets automatiques pour fixer la bâche à la benne soient dans une position correcte (1) et que les cordes élastiques soient accrochées aux crochets adaptés (2). **Il est absolument interdit de commencer à rouler sans avoir préalablement vérifié que les dispositifs de sécurité ont été positionnés correctement.**

www.marcolincovering.it



Chapter 3 HANDLING THE SYSTEM - OPERATIONS

3.1 Hand-operated version

3.1.1 Unfolding the Ecotype for covering the tipper body

In the starting operational situation, the covering is folded in the front of the tipper body; proceed as follows to unfold the covering:

- Check that the upper edges of the tipper body are free from any obstacle;
- Remove all the elastic strings (if provided in the version installed on your vehicle) from the frontal hooks so that the covering can move freely;
- Extract the safety cotter pin that locks the handling rod during road travel;
- Grip the handling rod using the specific handholds;
- Rotate the handling rod clockwise, making sure that sliding motion is homogeneous and fluid;
- Cover perfectly the total length of the tipper body with the cover;
- Close the covering at the back (this is automatic if there is the automatic rear closing device);
- Position again the handling rod in its specific housing and insert the safety cotter pin;
- According to the version installed on your vehicle, use the elastic strings to fasten the tarpaulin during road travel or check that the automatic lateral hooks are inserted in their specific U-bolts or housings;
- Carry out a brief but careful inspection to check that everything is in order before driving the vehicle on the road

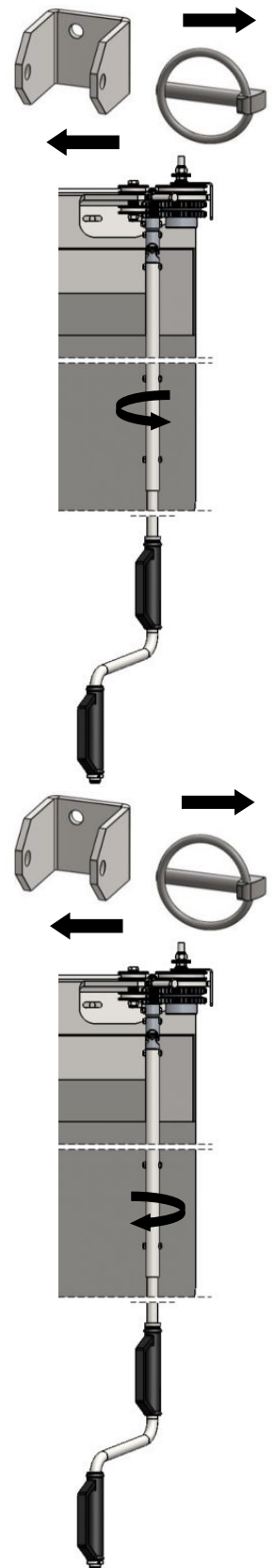

3.1.2 Folding the Ecotype for uncovering the tipper body

In the starting operational situation, the covering is unfolded on the tipper body; proceed as follows to fold again the covering:

- Remove all the elastic strings (if provided in the version installed on your vehicle) from the lateral hooking points so that the covering can move freely
- Extract the safety cotter pin that locks the handling rod during road travel;
- Grip the handling rod using the specific handholds;
- Rotate the handling rod counter clockwise, making sure that sliding motion is homogeneous and fluid;
- Uncover perfectly the total length of the tipper body;
- Fasten the elastic strings to the frontal hooks (if provided by the version installed on your vehicle);
- Fasten the handling rod to the specific support and then the safety cotter pin;
- Carry out a brief but careful inspection to check that everything is in order before starting the tip up lifting operation.

3.1.3 In case of empty tipper body

When the tipper body is completely empty, two distinct situations may occur:

- If you have to reload the tipper body in the same place in which it was unloaded, it is possible to keep the elastic hooks not hooked (always if your setup provides them), and then proceed with a new unfolding of the covering and their relative fastening operation;
- If you have to start travelling on the road with the empty tipper body, it is mandatory to position the elastic strings with hooks in their specific hooking points to prevent people or objects from getting snagged during road travel.
- Position the handling rod in the specific housing and insert the safety cotter pin;
- Carry out a brief but careful inspection to make sure that everything is in order before starting to drive the vehicle on the road.

3.2 Electrically operated version

3.2.1 Description of the Control Box

The Control Box consists of:

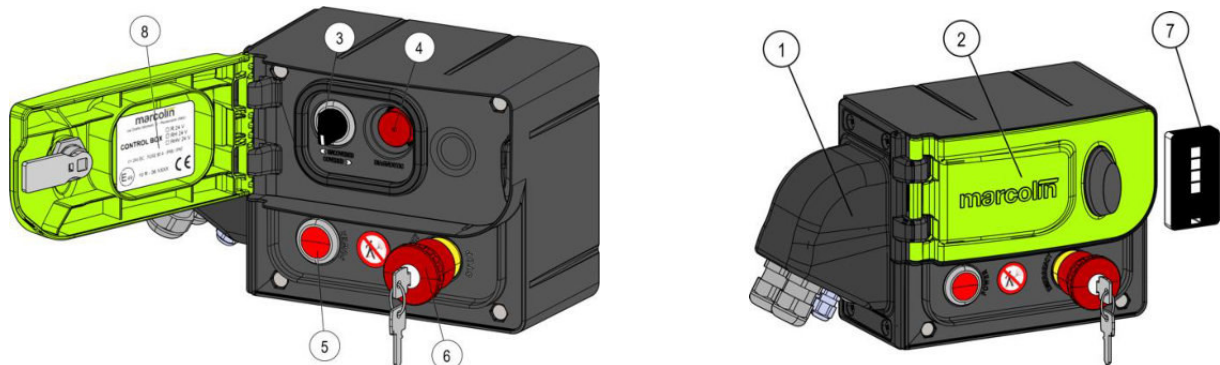

1. Cover for the contacts of the 24V power supply and motor connection cables.
2. Controls door
3. Latching control selector (**UNCOVERED / COVERED**)
4. Diagnostics socket
5. LED-lit button (power and "TX MARCOLIN" radio remote control programming)
6. Emergency button with safety key reset
7. 4-channel "TX MARCOLIN" radio remote control
8. Identification plate



WARNING!

It is strictly forbidden to operate the Control Box when the vehicle is in motion.
The manufacturer disclaims all responsibility.

3.2.2 Emergency pushbutton key, safety shutdown

The emergency pushbutton key is required for setting the machine in SAFETY SHUTDOWN to prevent that unauthorised personnel could start the machine. The safety shutdown must be always activated if the working of the covering system is not necessary (during day and overnight downtime, while executing maintenance or repair work, etc.), by pressing the emergency mushroom pushbutton and locking it with its specific key.



WARNING!

It is strictly forbidden to leave the machine running unattended.
The manufacturer denies any responsibility.

3.2.3 Control Box components that can be used by the operator

- **UNCOVERED** control switch / **COVERED** control switch;
- Emergency mushroom pushbutton with safety lock.
- LED-lit button (power and "TX MARCOLIN" radio remote control programming)
- "TX MARCOLIN" radio remote control.

3.2.4 Description of the remote control "TX MARCOLIN" system

The remote control "TX MARCOLIN" consists of a pocket remote control "TX MARCOLIN" to be used also as a key fob.

Operation of the buttons:

1. **UNCOVERED**
2. **COVERED**
3. Auxiliary control. If you have installed a Control Box model RHV 24 V, this button may be used to activate the vibrator)
4. Free auxiliary control

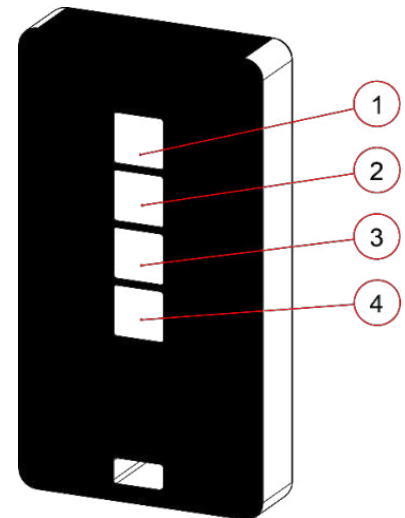

ORDINANCE!

The remote control "TX MARCOLIN" **MUST BE KEPT AND USED EXCLUSIVELY** by the operator.



After each use, the remote control "TX MARCOLIN" must be stored in a not accessible place.

Before using the remote control "TX MARCOLIN", the operator must verify the absence of any unauthorised personnel close to the Control Box.



WARNING!

It is absolutely forbidden to use the covering system with the remote control "TX MARCOLIN" when the vehicle is moving.

The constructor declines any responsibility.

3.2.5 Reprogramming the "TX MARCOLIN" radio remote control

Should it become necessary to reprogram the "TX MARCOLIN" radio remote control, please follow the procedure below.

1. Enter programming mode by pressing **7 times** the Control Box LED button (no. 5 in the figure). After having pressed the button 7 times, the Control Box will beep intermittently and the LED button will flash.
2. Now press any button of the "TX MARCOLIN" radio remote control: The Control Box will beep again and the LED button will turn off for one second, then it will turn back on and remain lit. The "TX MARCOLIN" radio remote control is now programmed.
3. Check the correct operation of the "TX MARCOLIN" radio remote control by testing the operation of the motor in the two directions by opening and closing the covering.

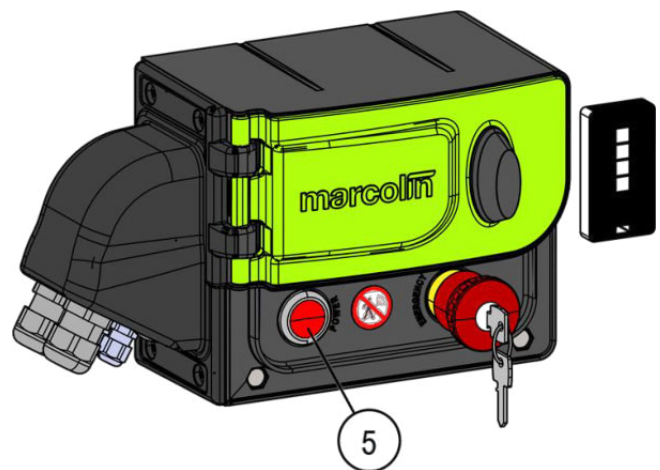

In case of errors or incorrect operation, contact Marcolin Covering Support Service or an authorized workshop.

3.2.6 Unfolding the Ecotype for covering the tipper body

In the starting operational situation, the covering is folded on the front part of the tipper body. To unfold it, operate as follows:

- Check that the upper edges of the tipper body are free from any obstacle.
- Remove all elastic strings (if provided for the version installed on your vehicle) from the frontal hooks so that the covering can be moved freely.
- Insert the key in the emergency pushbutton.
- Turn the key in CLOCKWISE direction to unlock the emergency mushroom pushbutton and give the consent to start the machine:
 - ❗ *When activating the Control Box, it gives out an acoustic signal.*
On remote control "TX MARCOLIN": PRESS the pushbutton no. 2 (COVERED)
On Control Box: TURN THE CONTROL SWITCH towards the right side (COVERED)
- Unfold the tarpaulin completely and release the control SWITCH or the control pushbutton. The Control Box is equipped with an automatic motor shutdown when the covering reaches the end stop.
- Close the covering on the rear side (in case of automatic rear closing system, this operation takes place automatically).
- Hook the elastic strings to the lateral hooking points to fasten the tarpaulin for the road travel (if provided for the version installed on the vehicle).
- Press the emergency mushroom pushbutton and remove the key.
- Carry out a brief but careful inspection, especially of the automatic lateral hooks, to make sure that everything is in order before starting to drive the vehicle on the road.

3.2.7 Interruption of machine operations

To stop the movement of the covering, release the control selector of the Control Box or release the button of the "TX MARCOLIN" radio remote control.

3.2.8 How can I stop the machine in case of emergency?

For setting the machine in **EMERGENCY STOP**, press instinctively the mushroom pushbutton stated as no. 6 on the Control Box.



WARNING!

It is strictly forbidden to leave the machine unattended while the system is active.
The manufacturer denies any responsibility.

3.2.9 Restoring of standard operative conditions



CAUTION!

Before restarting the machine correct the situation causing the event.

For restoring the machine after an emergency situation with pressing on the red mushroom pushbutton no. 6 proceed as follows:

- Insert the unlocking key in the emergency pushbutton of the Control Box
- Turn the key in clockwise direction and pull out the pushbutton.

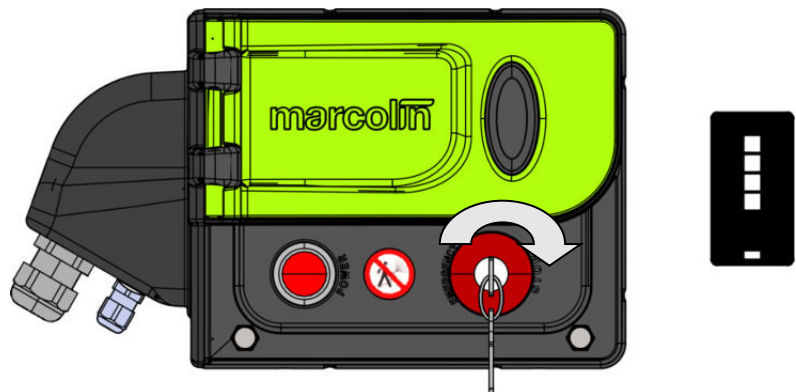

3.2.10 Machine stop in safety conditions

- Release the control selector of the Control Box or release the button of the "TX MARCOLIN" radio remote control".
- Set the machine in EMERGENCY STOP by pressing the mushroom pushbutton stated as no.6 on the Control Box.
- For setting the machine in SAFETY SHUTDOWN (if it is necessary to leave the vehicle unattended), remove the key from the emergency pushbutton (no. 6).

3.2.11 Folding the Ecotype for uncovering the tipper body

In the starting operational situation, the covering is extended on the tipper body; proceed as follows to fold again the covering:

- Remove all elastic strings (if provided for the version installed on your vehicle) from the lateral hooking points so that the covering can be moved freely.
- Insert the key in the emergency pushbutton.
- Turn the key in CLOCKWISE direction to unlock the emergency pushbutton for giving the consent to start the machine:
 - ⓘ *When activating the Control Box, it gives out an acoustic signal.*
 - On remote control "TX MARCOLIN":** PRESS the pushbutton no. 1 (UNCOVERED)
 - On Control Box:** TURN THE CONTROL SWITCH towards the left side (UNCOVERED)
- Fold the tarpaulin completely and release the control switch or the control pushbutton. The Control Box is equipped with an automatic motor shut-down when covering reaches the end stop.
- Carry out a quick but attentive control to verify that everything is in good order before starting the tilting movement of the tipper body.

3.2.12 How do you interrupt the machine operations?

Follow the process described in paragraph 3.2.7

3.2.13 How do you stop the machine in case of emergency?

Follow the process described in paragraph 3.2.8 .

3.2.14 Machine stop in safety conditions

Follow the process described in paragraph 0.

3.2.15 In case of empty tipper body

When the tipper body is completely empty, two different behaviours of the operator are required:

- If you have to reload the tipper body in the same place in which it was unloaded, it is possible to keep the elastic hooks not hooked (always if your setup provides them), and then proceed with a new unfolding of the covering and their relative fastening operation;
- If you have to start travelling on the road with the empty tipper body, it is mandatory to position the elastic strings with hooks in their specific anterior hooking points to prevent people or objects from getting snagged during road travel.
- Push the emergency pushbutton to set machine in SAFETY SHUTDOWN and remove the key.
- Carry out a brief but careful inspection to make sure that everything is in order before starting to drive the vehicle on the road.

3.3 Using the accessory equipment (if installed)

3.3.1 Automatic rear closing device

The possible presence of the automatic rear closing device avoids that the operator has to arrange manually the end part of the tarpaulin when securing the tipper body. With this device, the covering closes automatically when the covering reaches the end stop.

3.4 What has to be done if the covering does not work electrically?



WARNING!

It is forbidden to open the Control Box by removing the bottom cover.
Tampering will void the warranty.

3.4.1 Check and replacement of the internal fuse in emergency case

Before replacing the internal fuse, verify that the external one placed on the positive pole terminal (+) of the battery has not blown. Otherwise, that fuse needs to be replaced.

**IMPORTANT INFORMATION FOR USER SAFETY**

The replacement of the internal fuse in emergency case should be executed by the operator only as an exception. It is important to contact as a matter of priority, if the emergency situation allows it, the local installer for getting detailed information about the procedure to apply.



WARNING!

Before opening the cover of the contacts of the Control Unit, disconnect the battery to isolate the unit.



WARNING!

This procedure must be absolutely carried out by qualified personnel to avoid invalidation of warranty!

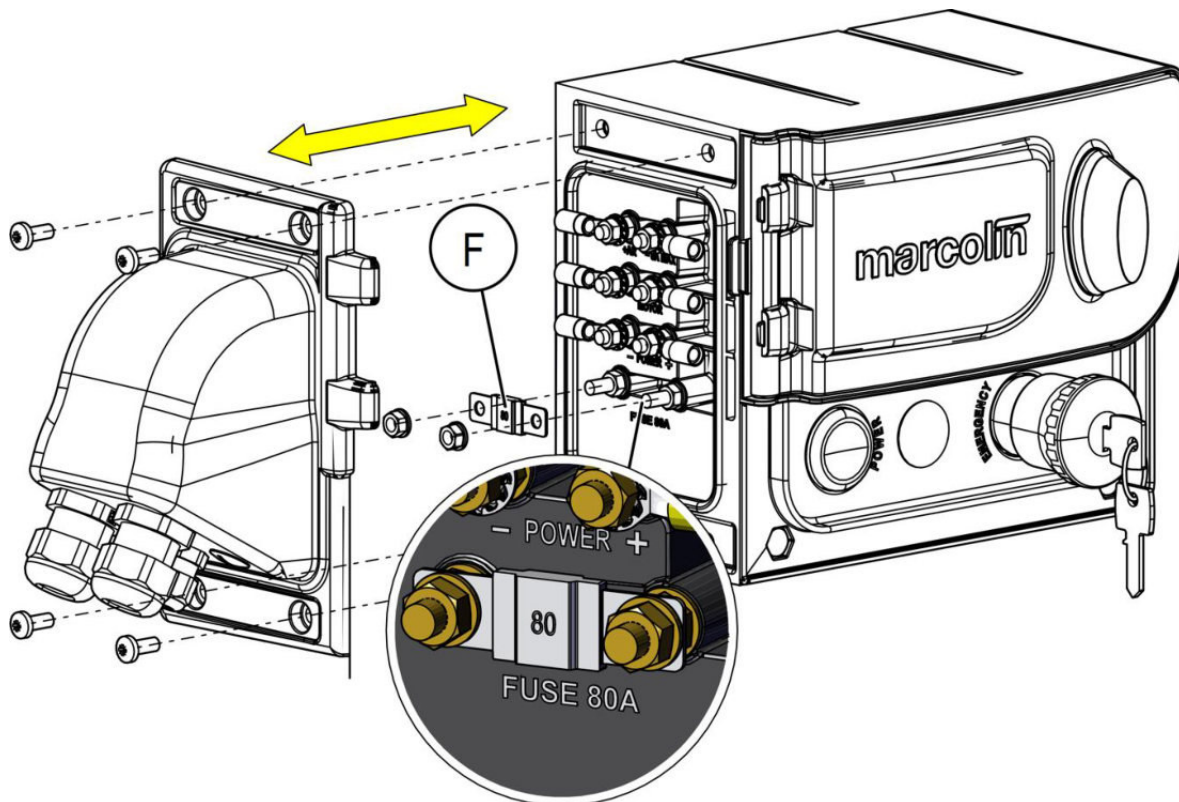

1. Using a suitable screwdriver, loosen the screws on the sides of the cable cover on the left side of the Control Box.
2. Remove the cover while taking care not to damage its gasket.
3. Replace the blown fuse (F).
4. Wait at least 8 hours before reclosing the cover, as the gasket needs a sufficient time to recover its shape. When closing the cover, be careful not to damage the gasket.

Chapter 4 MAINTENANCE WORK OF THE ECOTYPE COVERING SYSTEM

4.1 Introduction

Maintenance is one of the most important operations among those carried out on machines.

It is necessary to do a methodical, systematic, and conscientious maintenance programme that will make your machine work properly and in safe conditions.

Good maintenance lengthens the life of the machine and delays its substitution.

4.2 Safety Norms



WARNING!

To carry out certain maintenance operations, it is necessary to access the inside of the tipper body; make sure that it is empty and clean to avoid slips and falls. Wear personal protective equipment (PPE).

ALL MAINTENANCE OPERATIONS MUST BE CARRIED OUT WITH THE MACHINE IDLE AND PLANT DEACTIVATED.

Put out the "Machine under maintenance" sign.

The manufacturer denies any responsibility.

Do not carry out "DIY" type interventions; the machines are dangerous and must be treated by competent and trained personnel.

Any replacement of components must be carried out using exclusively original spare parts so as not to compromise the machine optimal functioning and safety.

4.3 Instructions on washing the machine

Washing must be carried out in a proper structure complying with laws in force on safety and environmental respect. Before proceeding with washing, position the machine in a stable manner and carefully inspect the working area (if there are people, objects or animals). Wear personal protective equipment.



WARNING!

Do not point the high-pressure jet too long on areas containing electric components.



WARNING!

Do not use detergents that are detrimental to health and to machine components.

4.4 Ordinary maintenance

 The ordinary maintenance must be carried out by the machine's owner, within the deadlines set out in this manual.

4.4.1 General tightening up of the screw connections

After the first 20/30 operating hours and later on every three months, the screw connections have to be checked for excluding any loosening on the machine and make the tightening up where needed.



WARNING!

Firmly tighten all bolts and screws of the covering!

OPERATION	ORDINARY MAINTENANCE	EXTRAORDINARY MAINTENANCE
GENERAL TIGHTENING UP OF THE SCREW CONNECTIONS	First tightening after 20/30 working hours, then quarterly	Yearly c/o manufacturer or authorised workshop

4.4.2 Check the conservation status of metal structure and bows

OPERATION	ORDINARY MAINTENANCE	EXTRAORDINARY MAINTENANCE
CHECK METAL STRUCTURE AND BOWS	quarterly	Yearly c/o manufacturer or authorised workshop



WARNING!

If damages are ascertained, DO NOT START THE MACHINE,
bring it to a Marcolin's authorised workshop.

4.4.3 Check the tarpaulin conservation status

OPERATION	ORDINARY MAINTENANCE	EXTRAORDINARY MAINTENANCE
CHECK TARPAULIN	quarterly	Yearly c/o manufacturer or authorised workshop

Check especially the wear and tear status of the most stressed parts like the front hooking and the lateral fastening of the bows.

4.4.4 Check the cables' tensioning and conservation status

20/30 hours after assembling the covering system, tighten up again the cables.

OPERATION	ORDINARY MAINTENANCE	EXTRAORDINARY MAINTENANCE
CHECK CABLES	Weekly	Yearly c/o manufacturer or authorised workshop

Most of all, make sure that the cables are not frayed. If so, go to an authorised workshop for replacement.

Check also that the cable torque is correct at 7 Nm.

4.4.5 Lubricate and grease

OPERATION	ORDINARY MAINTENANCE	EXTRAORDINARY MAINTENANCE
GENERAL LUBRICATION	weekly	Yearly c/o manufacturer or authorised workshop

- 1) GREASE THE INTERNAL COUPLING BETWEEN PINION AND GEAR (manual version)

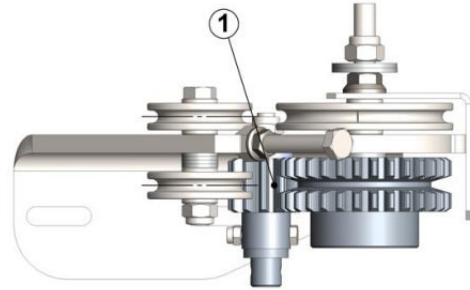

i Make use of lithium-based grease.

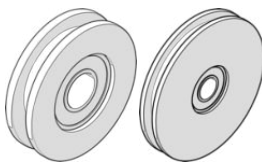

IMPORTANT!

CLEAN AND LUBRICATE THE VARIOUS PULLEYS LOCATED ON THE MACHINE, ALSO CABLES, GROOVES AND SLOTS OF THE PULLEYS, BY APPLYING SVITOL® or WD-40 LUBRICATING OIL OR A SIMILAR PRODUCT.

4.4.6 Check the elastic strings with hooks or the automatic lateral hooks (only if installed)

20/30 hours after assembling the system, carry out the following operations.

OPERATION	ORDINARY MAINTENANCE	EXTRAORDINARY MAINTENANCE
CHECK ELASTIC STRINGS OR AUTOMATIC LATERAL HOOKS	monthly	Yearly c/o manufacturer or authorised workshop

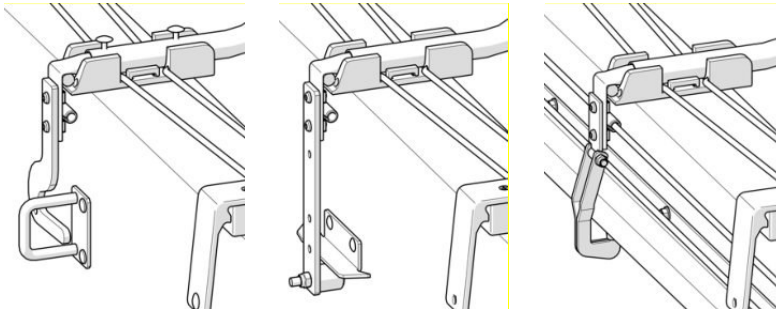

Check the conservation status of the hooking components. If necessary, provide for their replacement.

4.4.7 Replace broken or damaged fastening hooks on the outer board wall (only if installed)

OPERATION	ORDINARY MAINTENANCE	EXTRAORDINARY MAINTENANCE
CHECK FASTENING HOOKS	monthly	Yearly c/o manufacturer or authorised workshop

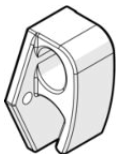

- Replace the hooks at the first sign of wear and tear.

4.4.8 Check the contact plates (only if installed)

OPERATION	ORDINARY MAINTENANCE	EXTRAORDINARY MAINTENANCE
CHECK CONTACT PLATES	every fifteen days	Yearly c/o manufacturer or authorised workshop

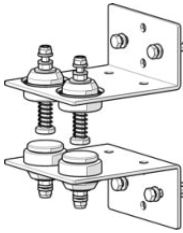

- Check the conservation status of the contact plates (if installed, only for motorized covering system), and if necessary provide for their cleaning.
- Protect the contacts using synthetic moisture-repellent grease.

4.4.9 Check the sliding paths of the covering

OPERATION	ORDINARY MAINTENANCE	EXTRAORDINARY MAINTENANCE
CHECK SLIDING CONDITIONS	monthly	Yearly c/o manufacturer or authorised workshop

Check that the upper edges of the tipper body are free of damage and straight-line (absence of breaches on the locating surface) so that the covering doesn't hit upon any defects while sliding.

4.4.10 Check the pulleys

OPERATION	ORDINARY MAINTENANCE	EXTRAORDINARY MAINTENANCE
CHECK PULLEYS	monthly	Yearly c/o manufacturer or authorised workshop

Check that the various pulleys, Ø60 and Ø100, are free of damage so that the covering can slide properly and regularly without meeting any anomaly.

4.5 Ordinary maintenance that can be carried out exclusively by operators equipped with the installer's manual

i In case of great fleet with an own workshop, it is possible to request the installation manual to Marcolin Covering s.r.l..

4.5.1 Bow replacement

For replacing a bow proceed as follows:



WARNING!

In case of electrically operated covering system, before every maintenance work, take care to activate the safety shutdown with the key. As soon as the maintenance or repairing work has been performed remember to remove the key from the emergency mushroom pushbutton.

- Find out the bow that needs to be replaced;
- Remove the rivets positioned on the tarpaulin upper side which fasten the bow to the bow support

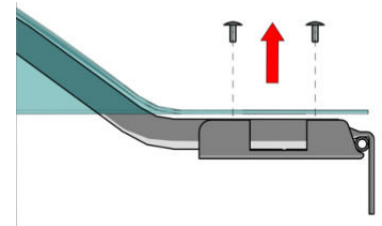

Caution
Maintenance in progress

WARNING!

For carrying out certain maintenance work the access to the internal space of the tipper body is required. Make sure that the internal space is empty and clean to avoid any sliding and falling. Wear suitable protective clothing.

ALL MAINTENANCE OPERATIONS MUST BE CARRIED OUT WITH THE MACHINE IDLE AND PLANT DEACTIVATED!

DO NOT WALK ON THE TARPAULIN!
Put a "Machine under maintenance" sign out.

The manufacturer denies any responsibility.

- From inside the tipper body remove the plastic ties that fasten the tarpaulin to the bow.
- Undo the self-threading screws which fasten the bow to its support
- Carry out the described operation on both sides;
- Pull out both bow supports and remove the bow.;

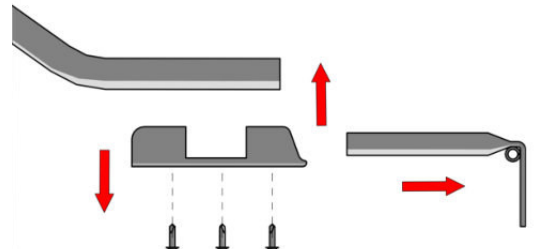

At this point the damaged bow has been removed and the new one can be assembled.

- Insert both supports in the respective end parts of the bow taking care that the passage axis of the cables is the same of the others;
- Fasten the supports using the suitable self-tapping screws;
- Inside the tipper body fasten the tarpaulin to the bow by using common cable ties (in case of fire-resisting PVC-tarpaulin or neoprene apply fire-resisting cable ties);

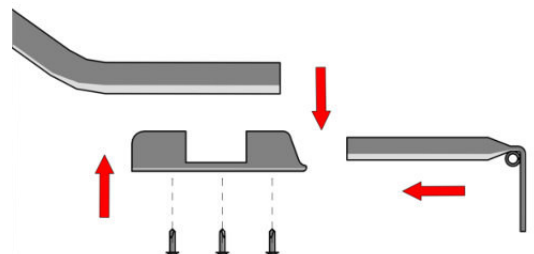

WARNING!

For fireproof PVC tarpaulins, the application of standard plastic ties is not permitted. Request to the manufacturer the proper plastic ties for fireproof tarpaulins.
The manufacturer denies any responsibility.

- Reposition the rivets for fastening the tarpaulin and the PE flat strip to the support.
- After the replacement of the bow, the covering system is ready for use.

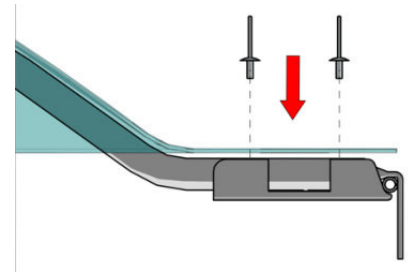

Note: In case of electrically operated handling system remember to restore the emergency case standby by unlocking using the relative key.

4.5.2 Tarpaulin replacement

- Remove the rivets on the outside part of the tarpaulin that fasten it to the supports of the bows;

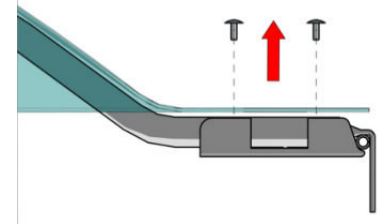

WARNING!

For carrying out certain maintenance work the access to the internal space of the tipper body is required. Make sure that the internal space is empty and clean to avoid any sliding and falling.
Wear suitable protective clothing.

DO NOT WALK ON THE TARPULIN!

The manufacturer denies any responsibility.

- On the frontside of the tipper body remove the aluminium flat bar that fastens the tarpaulin and pull out the plastic flat strip.
- Inside the tipper body, remove the plastic ties that fasten the tarpaulin to the bows
- Remove the damaged tarpaulin.
- Proceed to position the new tarpaulin.
- Inside the tipper body, fasten the tarpaulin to the various bows by using common cable ties for standard PVC tarpaulins.



CAUTION!

For fireproof PVC tarpaulins, the application of standard plastic ties is not permitted. Request to the manufacturer the proper plastic ties for fireproof tarpaulins.
The manufacturer denies any responsibility.

- Reinsert the plastic flat strip inside the tarpaulin lateral sleeves.
- Reposition the rivets that keep the tarpaulin in place.
- Tighten up the front part of the tarpaulin.
- Fasten the tarpaulin on the top of the gear housing by using specific aluminium flat bar and rivets.
- Cut the excess tarpaulin part off.

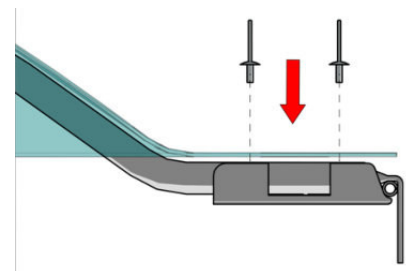

4.5.3 Steel cables replacement



IMPORTANT!

The steel cable must be replaced in the presence of trained and competent personnel.

When replacing the cables, it is important to remember that they are the main element that permits the correct action of the tipper body covering.



WARNING!

This activity is one of the most important for the proper working of the covering. The better the alignment, the easier the handling of the tarpaulin, in case of manually operated version, and the lesser the motor effort in case of electrically operated version.



WARNING!

During installation of the metal cable, it is strictly mandatory to wear gloves in order to prevent hand injuring caused by the possible fraying of the metal mesh.

Removing the cable:

To properly remove the cable it is necessary to operate on the Left and Right front supports. Operating alternately on the two supports, proceed as follows:

- Unblock the cable loosening the central screw (3) on the support.
- Using a torque wrench loosen the screw placed on the front side (1) of the support. As a consequence the pulley (2) moves forward loosening the steel cable.

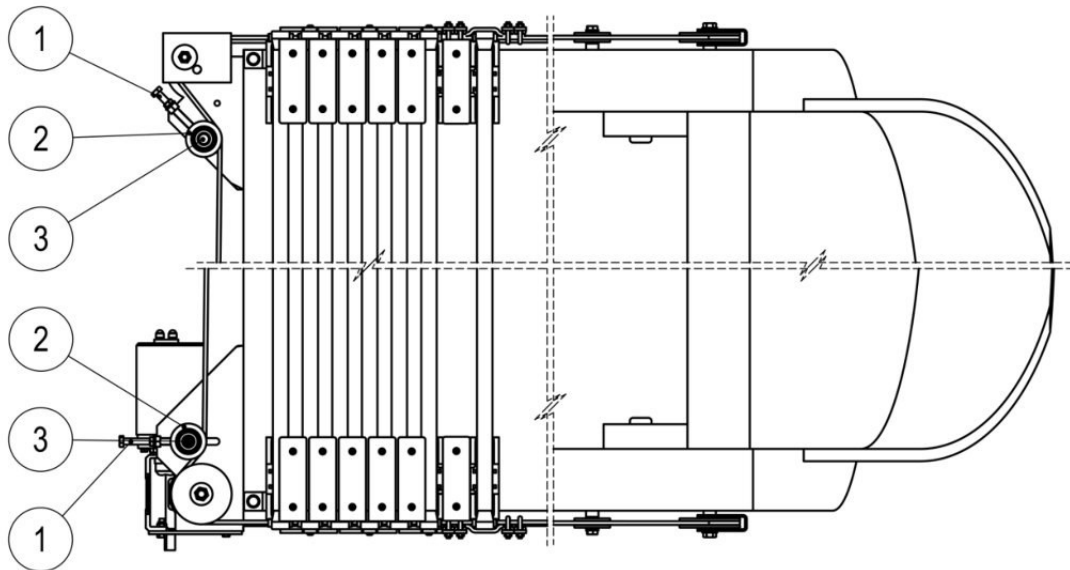

Now you need to release the steel cable from the covering pulling bow's feet.

- Loosen the clamps (6) on both sides of the pulling bow (4) and pass both ends of the cable out the clamps.
- Take the cable which returns from the rear pulley back (7) and pass it all the way out at the outside of the pulling bow support.
- Pass out the steel cable (8) from the hole of all bows feet.

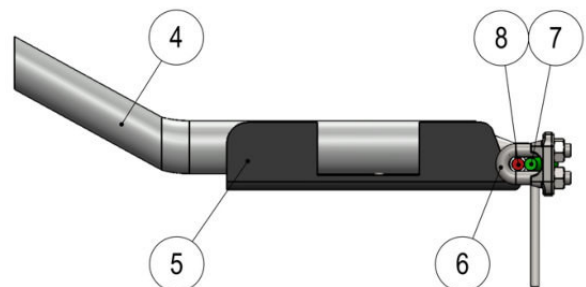

Running the steel cable:

Follow the instructions given below for the placement of the steel cable.

For the sake of convenience insert the entire length of the steel cable, between the various elements, operating as shown in the following figures.

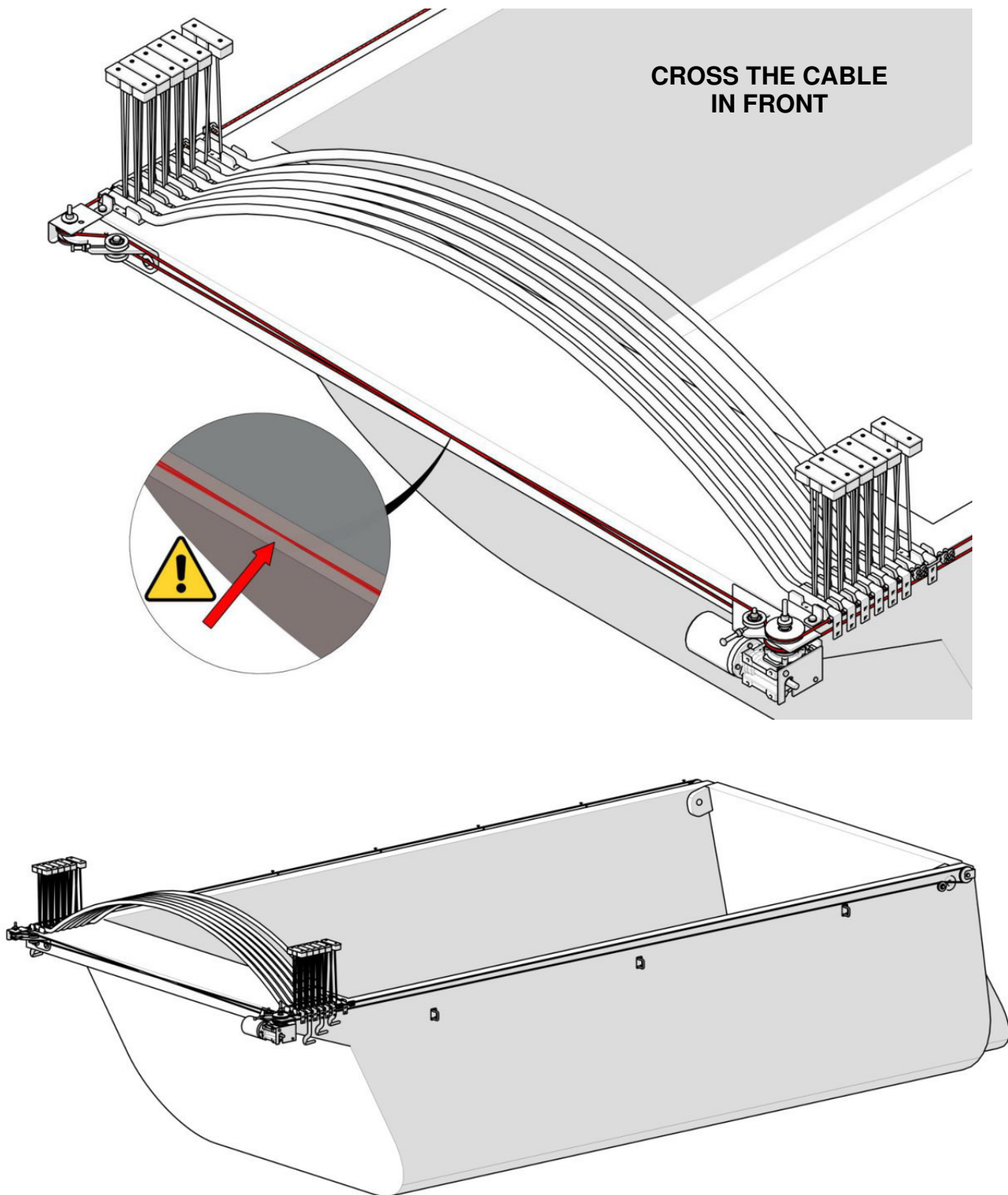

Note: The position of the cable is the same, both for the manual and motorised versions.

Note:

In the absence of our directive specifications, the cable must be passed through the hole where the steel bushing is located

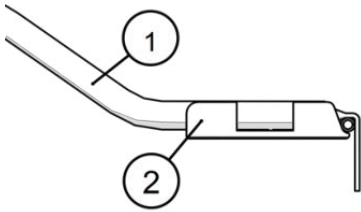

The bows holding up the tarpaulin have on their ends suitable supports for an easy sliding of the covering along the upper edge of the tipper body. These supports have at their outside a clearance hole through which the cable of the handling system runs.

- 1) BOW
- 2) BOW SUPPORT WITH SLIDING PART

Using the head of the upper cable, proceed as shown:

- Insert the steel cable onto all the bows through the hole on their support;
- Last of all, insert the head of the cable into the pulling bow support hole;
- Make sure that there is at least 100-150 mm left of the back end of the cable for further fixing and any correction.

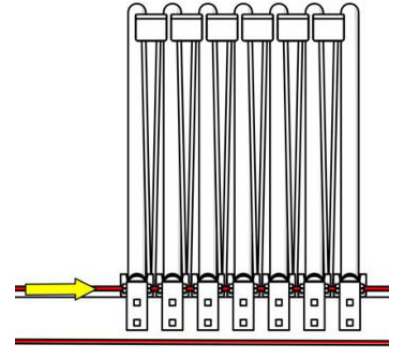
**Note:**

Ensure that the bow keeps as perpendicular as possible to the board walls for avoiding any subsequent adjustment service.

Positioning of the lower steel cable end:

- Put the head of the metallic cable onto the back of the case;
- Wrap the cable onto the back pulley;
- Come back with the end of the steel cable towards the draw arc foot hole.

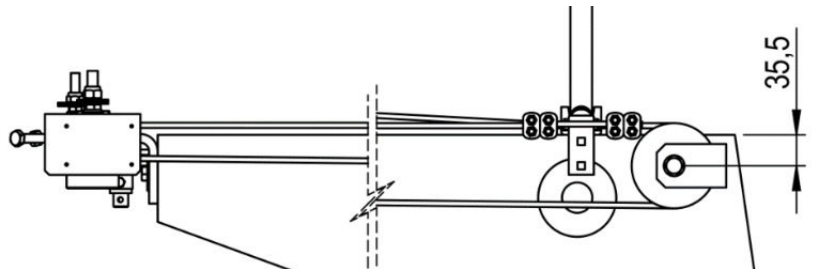
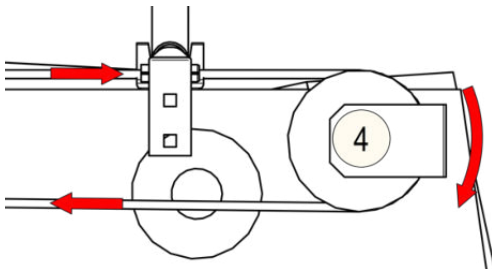

Cable fastening:

Now that the steel cable has been properly positioned on its path, the cable fixing activities can be carried out.



CAUTION!

During the installing activities of the steel cable the use of suitable protective gloves is mandatory in order to avoid any injury to hands due to a possible fraying of the steel cable mesh.

Note: Before fastening the cable, check carefully whether the covering is equipped with a single or double pulling bow.

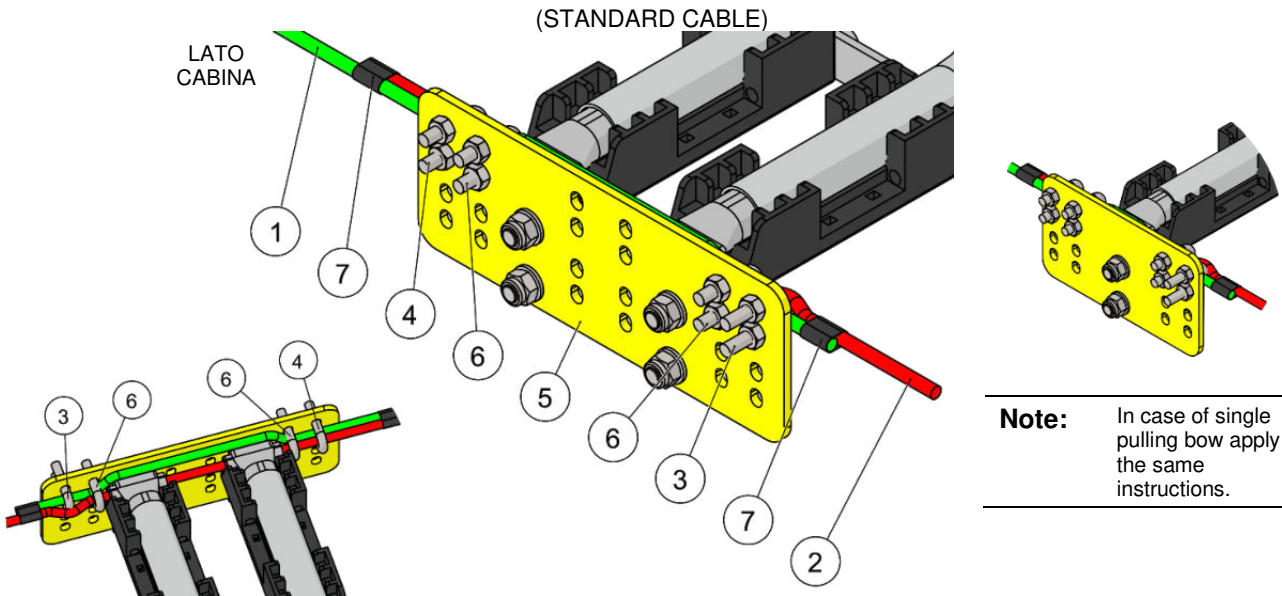

Note: In case of single pulling bow apply the same instructions.

1. Insert a clamp (3) in the inner side of the support plate of the double pulling bow (5).
2. Take the end of the cable (1) which comes back from the vehicle cab side and fasten it with the clamp (3). Before tightening the clamp (3), pull the cable manually for tensioning it.
3. Take the end of the cable which comes back from the rear side of the vehicle (pulley side) (2), overlap the first one (1) passing it through the inner side of the support plate (5).
4. Fasten both cable ends (2) and (1) with a clamp (4) inserted in the inner side of the support plate (5). Before tightening the clamp (4), pull the cable manually for tensioning it.
5. For greater safety, it is mandatory to fasten both cables with two additional clamps (6).
6. Wrap up with a loop of electrical tape (7) the cable end which comes from the vehicle cab side (1) and the one coming from the pulley side (2). Repeat the same operation with the other cable end.

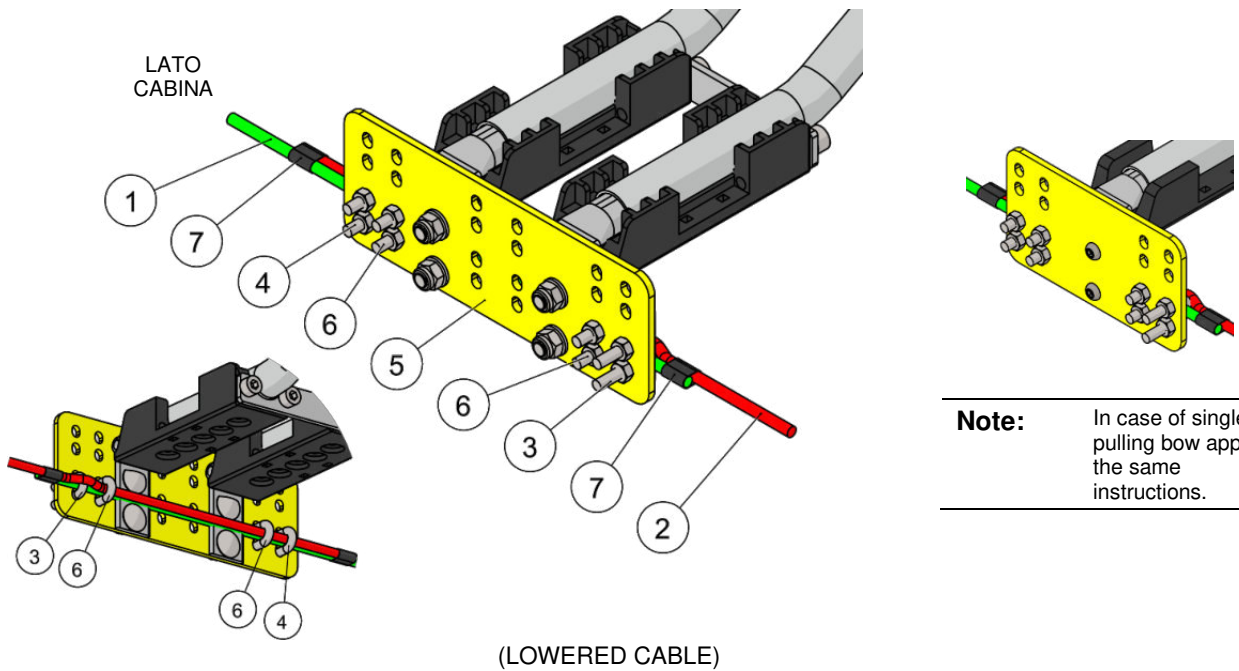

Note: In case of single pulling bow apply the same instructions.

WARNING!

IT IS FORBIDDEN TO use different materials than those supplied by the system to avoid invalidation of warranty.

The cables must be secured by 4 galvanized steel clamps for Ø 6 rope, placed as shown in the figures above (i.e., 2 on each side).

WARNING!

An incorrect fixing of clamps, the lack of one or more clamps as well as a different fixing process from the described one can compromise the tarpaulin stability on the tipper body, causing its separation with danger and damages to persons and objects.

IT IS FORBIDDEN TO use different materials than those supplied by the system to avoid invalidation of warranty.

7. After having fixed the steel cable cut the excess length off but leaving about 100-150 mm usable for any necessary adjustments.

Note: Prior to cutting the cable wrap the cut surface with insulating tape to prevent a possible fraying.

Clamping the pulling bow

At this point it is necessary to fasten the bow also on the opposite side by means of the clamps supplied, to allow pulling the covering.

1. Make sure that the last bow (1) (the one near the rear part of the body) is straight (parallel with respect to the front panel).
2. Measure the length (L) from the beginning of the body to the bow on which the clamps (2) have already been fixed.
3. Bring the opposite side to the same measurement and fix with two clamps as shown in the figure.
4. Fasten the steel-wire rope to the foot of the pulling bow as described above.

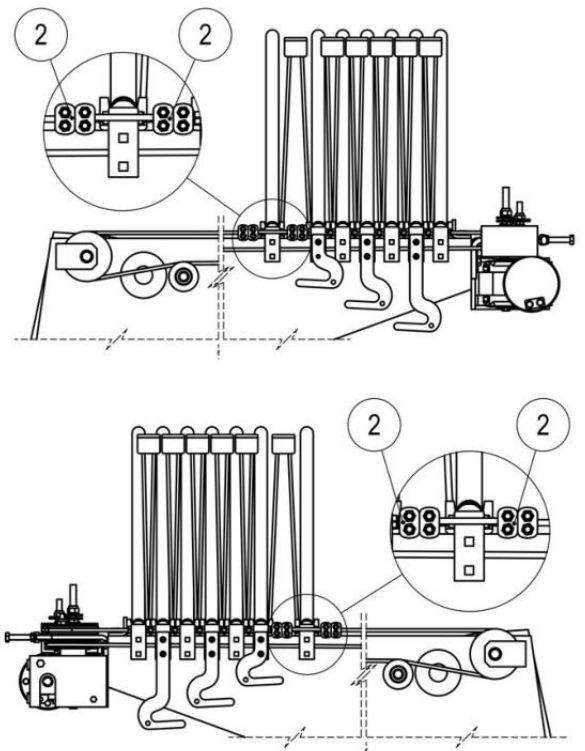
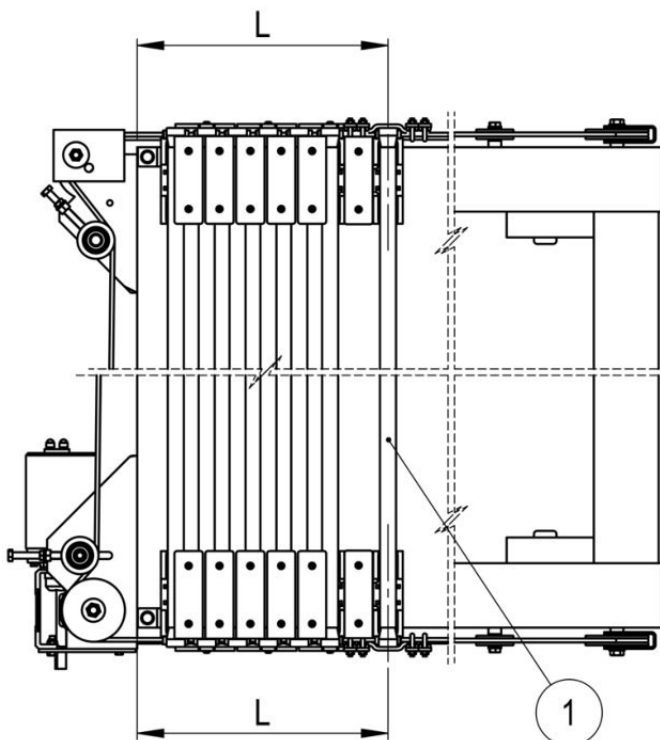

Steel cable tightening up

After positioning the steel cable tight it up in order to make a proper sliding of the covering possible.

As a matter of fact the Left and Right front supports have been developed and manufactured with the aim to allow the operator steel cable tension adjustments.

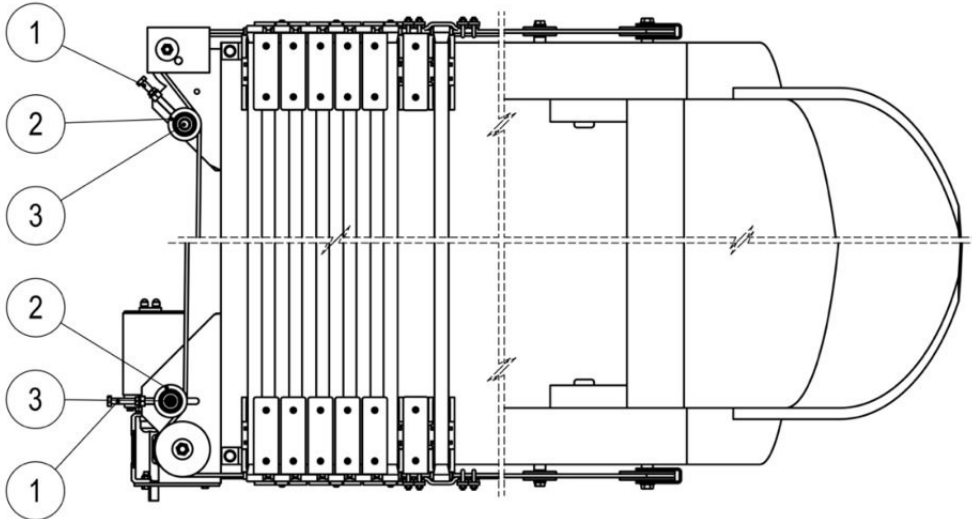

Operating alternately on the two supports, proceed as follows:

1. Use a 7 Nm torque wrench to tighten the screw placed on the front side (1) of the LH support. As a consequence the pulley (2) moves backwards tightening up the steel cable.
2. Act alternately on one support and on the other one, tightening up the cable in the same way on both sides;
3. When the required tension is achieved block the guide pulley tightening the central screw (3).



WARNING!

During installation of the metal cable, it is strictly mandatory to wear gloves in order to prevent hand injuring caused by the possible fraying of the metal mesh.



IMPORTANT!

Once terminated this operation **make sure that the bow is perpendicular to the side board and at equal distance from the tailgate**. If not, operate consequently on the tensioning device of the steel cable or, if necessary, proceed to block it.

4.5.4 Repositioning the covering

Because of flaws on the tipper body (blows, recesses etc.) or its incorrect loading, the covering may move sideways when used. In this case, act as follows to reposition it correctly:



WARNING!

During installation of the metal cable, it is strictly mandatory to wear gloves in order to prevent hand injuring caused by the possible fraying of the metal mesh.

Spray all the pulleys of the covering with Svitol to ease the following operations:

1. Fold up the covering into the front part of the tipper body;
2. Loosen both rear tensioner plates;
3. Push manually the last bow towards the front part, on both sides, until there is the same distance between the last bow and the right and left gear housings.
4. If the covering is manually operated, make sure that the operating rod is fastened in its housing.
5. Re-tighten the cables.

4.6 Troubleshooting table for electrically operated covering system

The following table lists some possible breakdowns or operating troubles.



As you will see, user intervention is allowed only in some particular cases. For all other circumstances, turn to an authorised workshop.

Every time you request authorised assistance, pay attention to keep in mind the covering's serial number that you can find on the metal plate affixed to the gear protective metal cover and in the documentation delivered at the time of purchase.

Type of fault	Possible cause	Possible solution
The motor is not running after pressing a button of the "TX MARCOLIN" radio remote control or turning the control selector of the Control Box.	Emergency engaged.	Check the emergency button. If pressed, reset it by turning the key. ✓ Operation permitted to user.
	Incorrect electrical connections	Check the electrical connections (positive – negative) from the battery to the control box terminals. ✗ Operation NOT permitted to user. Contact Marcolin Technical Support or an authorized workshop to repair the connections.
	The safety fuse has blown.	✗ Operation NOT permitted to user unless previously authorised by Marcolin Covering s.r.l. or an authorized workshop. Check the fuses. One is located in line with the power supply (battery), the other is inside the Control Box.
	The contacts of the motor have become disconnected.	Check that the contacts of the motor are firmly connected. ✗ Operation NOT permitted to user. Contact Marcolin Technical Support or an authorized workshop.
	Problems inside the Control Box.	Contact the manufacturer or authorized personnel for assistance.
When you press a button on the "TX MARCOLIN" radio remote control, the red indicator light does not come on.	The battery of the "TX MARCOLIN" radio remote control is flat.	Replace the battery of the "TX MARCOLIN" radio remote control. ✓ Operation permitted to user. If the case, reprogram the "TX MARCOLIN" radio remote control following the instructions described at para. 3.2.5

<p>The Control Box operates only with the control selector and not with the “TX MARCOLIN” radio remote control.</p>	<p>The “TX MARCOLIN” radio remote control has lost the correct programming.</p>	<p>Reprogram the “TX MARCOLIN” radio remote control following the instructions described at para. 3.2.5</p> <p>✓ Operation permitted to user. If, after reprogramming, the radio remote control continues not to work, check the Control Box for faults.</p> <p>✗ Operation NOT permitted to user. Contact Marcolin Technical Support or an authorized workshop.</p>
<p>The Control Box appears to be working (you can hear its relay acting) but the motor is not running.</p>	<p>The electrical contacts may be oxidised. WARNING! Isolate the power supply before cleaning.</p>	<p>WARNING! Isolate the power supply before cleaning (press the emergency button or disconnect the plug from the tractor).</p> <p>✓ Operation permitted to user</p> <p>Check that the electrical contacts of the contact plate (between body and frame) are not dirty or oxidised. Check that the electrical contacts of motor and Control Box are not dirty or oxidised. If necessary, clean with a dry cloth and protect with synthetic moisture-repellent grease. Stubborn oxidation may be removed using very fine sandpaper (400 or finer)</p>
	<p>Burnt motor</p>	<p>Replace the motor.</p> <p>✗ Contact Marcolin Technical Support or an authorized workshop for the replacement of the motor</p>
	<p>A cable terminal or an eyelet of an electrical wire might have broken, or the electrical cables might be broken or damaged</p>	<p>Check the cable terminals on the cables of the motor and the contact plate are not damaged or broken. Check that the wiring is free from faults.</p> <p>✗ Contact Marcolin Technical Support or an authorized workshop to rectify the fault in the circuit by replacing the damaged components.</p>
<p>When you turn the control selector to “UNCOVERED”, the covering covers the body instead of uncovering it.</p>	<p>The polarity of the motor is reversed</p>	<p>WARNING! Isolate the power supply to the Control Box beforehand (press the emergency button or disconnect the plug from the tractor).</p> <p>✗ Contact Marcolin Technical Support or an authorized workshop to reverse the two wires connected to contacts 3-4 of the Control Box.</p>

4.7 Extraordinary maintenance work

-  Extraordinary maintenance is essential to have always a functional, integral and safe covering system.
-  Extraordinary maintenance must be performed at least once a year, by the manufacturer or by one of its authorised workshops.

4.8 Important information for the machine management

4.8.1 Machine disassembly and demolition

When the working life of the system has come to the end, proceed with disassembly, separating the materials by type.

Generally, the following types of material can be identified: building steel; plastics; lubricants; electronic material; rubber and derivate; varnish etc. Protecting the environment is very important and for this reason, the components listed above must be sent to expressly authorised institution for their disposal/recycling.

4.8.2 Machine noisiness

The machine does not produce noise loud enough to disturb human hearing.

4.8.3 Vibrations

The machine does not produce vibrations.

4.8.4 Modifying the machine

It is absolutely forbidden to make changes to the machine (see paragraph 1.6).

4.8.5 Transporting the covering

It is not expected for the user to transport separately the covering system.

4.8.6 Check register, maintenance tables

You can find them in Chapter 5 of this manual. We advise to use it for transcribing the succession of planned and extraordinary maintenance: remembering everything by heart is difficult.

Chapter 5 MACHINE CHECK REGISTER

5.1 Introduction to the check register

In this check register, specific for the machine purchased, you will find all the information useful for keeping your machine efficient and the apposite tables in which to record, every time, planned maintenance and yearly extraordinary maintenance.

5.2 Planned maintenance check register

5.2.1 List of operations

Refer to Chapter 4 that is completely dedicated to the planned maintenance operations and to the research of faults as a trace for the possible localization of functioning anomalies, which have to be notified to the manufacturer for getting the qualified personnel service.

5.2.2 Register of the maintenance intervention carried out on the machine

i The user must create a register of the maintenance interventions, taking some photocopies of the following printouts and filling them in for every maintenance intervention done.

OPERATIONS CARRIED OUT	REPLACED COMPONENTS
<input type="checkbox"/> Planned maintenance as prescribed in Chapter 4 of this manual. <input type="checkbox"/> Further operations carried out:
DATE OF INTERVENTION:	SIGNATURE OF MAINTENANCE TECHNICIAN

OPERATIONS CARRIED OUT	REPLACED COMPONENTS
<input type="checkbox"/> Planned maintenance as prescribed in Chapter 4 of this manual. <input type="checkbox"/> Further operations carried out:
DATE OF INTERVENTION:	SIGNATURE OF MAINTENANCE TECHNICIAN

i Before using this printout, we suggest to take some photocopies of it and insert them into the register of the maintenance interventions

OPERATIONS CARRIED OUT	REPLACED COMPONENTS
<input type="checkbox"/> Planned maintenance as prescribed in Chapter 4 of this manual. <input type="checkbox"/> Further operations carried out:
DATE OF INTERVENTION:	SIGNATURE OF MAINTENANCE TECHNICIAN

OPERATIONS CARRIED OUT	REPLACED COMPONENTS
<input type="checkbox"/> Planned maintenance as prescribed in Chapter 4 of this manual. <input type="checkbox"/> Further operations carried out:
DATE OF INTERVENTION:	SIGNATURE OF MAINTENANCE TECHNICIAN

OPERATIONS CARRIED OUT	REPLACED COMPONENTS
<input type="checkbox"/> Planned maintenance as prescribed in Chapter 4 of this manual. <input type="checkbox"/> Further operations carried out:
DATE OF INTERVENTION:	SIGNATURE OF MAINTENANCE TECHNICIAN

5.3 Yearly extraordinary maintenance check register

5.3.1 Authorised workshops, retail outlets, spare parts, assistance and installation

Yearly extraordinary maintenance must be carried out by Marcoling Covering s.r.l. or authorised workshops only.

To be informed on authorised workshops, retailers, worldwide installations, please call number +39 0434 570261 or send an e-mail to: info@marcolinsrl.it.

5.3.2 List of operations to be carried out by the authorised workshop

MECHANICAL COMPONENTS

COMPONENT	OPERATION TO BE CARRIED OUT	OBSERVATIONS
Nuts and bolts in general	<ul style="list-style-type: none"> Tightening and check state of conservation. 	<ul style="list-style-type: none"> Replace at the first signs of wear.
Sliding devices, evenness of the upper case etc.	<ul style="list-style-type: none"> Check conditions. 	<ul style="list-style-type: none"> Replace worn components.
Attachments for hooking the covering	<ul style="list-style-type: none"> State of conservation. Presence of all the hooks. Correct attachment of safety systems. 	
Pins and ferrules in general, pinion and gear, sliding parts etc.	<ul style="list-style-type: none"> State of conservation. Lubricate. 	<ul style="list-style-type: none"> When in doubt, replace.
General metalwork	<ul style="list-style-type: none"> State of conservation of protective treatments. Integrity of metalwork, absence of cracks or breaks. 	<ul style="list-style-type: none"> Proceed with the immediate replacement of damaged parts.
Elastics with hooks to lock the tarpaulin in place	<ul style="list-style-type: none"> State of conservation. Presence of all the elastics. 	
Covering's tarpaulin	<ul style="list-style-type: none"> Detailed check. 	<ul style="list-style-type: none"> Replace, if not, censure hermetic seal.
Cables and sliding feet, pulleys	<ul style="list-style-type: none"> Detailed check. 	<ul style="list-style-type: none"> Replace in the case of frayed cables or worn feet or pulleys not ensuring homogeneous and linear slide.

ELECTRIC COMPONENTS

COMPONENT	OPERATION TO BE CARRIED OUT	OBSERVATIONS
Switches, activating devices, sensors, contact devices, mushroom emergency button etc.	<ul style="list-style-type: none"> Test intervention efficiency and check state of conservation. 	
Power supply lines	<ul style="list-style-type: none"> Check state of conservation and that there is no component oxidation. 	
Electric device protections	<ul style="list-style-type: none"> Verify integrity. 	
Control panel	<ul style="list-style-type: none"> Verify component efficiency and integrity. 	
Radio control batteries	<ul style="list-style-type: none"> Check that there is a spare battery on board. 	<ul style="list-style-type: none"> Supply a spare battery if there is not one on board.

SAFETY SIGNS

COMPONENT	OPERATION TO BE CARRIED OUT	OBSERVATIONS
Warning and instruction signs	<ul style="list-style-type: none"> Check presence, legibility, integrity and suitability. 	<ul style="list-style-type: none"> Replace immediately if deteriorated.
Lit signals	<ul style="list-style-type: none"> Verify operation. 	
Check register	<ul style="list-style-type: none"> Update. 	

5.3.3 Register of annual checks carried out

i The user must create a register by taking some photocopies of the following printouts, filling them in at occurrence, making them stamped and signed by the authorised workshop.

CARRIED OUT OPERATIONS	REPLACED COMPONENTS
<p>DATE OF INTERVENTION:</p> <p><input type="checkbox"/> The covering system has been subjected to the yearly extraordinary maintenance.</p> <p><input type="checkbox"/> Further operations carried out:</p> <p>.....</p> <p>.....</p> <p>.....</p> <p>.....</p> <p>.....</p> <p>.....</p> <p>.....</p>	<p>.....</p> <p>.....</p> <p>.....</p> <p>.....</p> <p>.....</p> <p style="text-align: center;">STAMP AND SIGNATURE OF THE AUTHORISED WORKSHOP</p> <p>.....</p>

CARRIED OUT OPERATIONS	REPLACED COMPONENTS
<p>DATE OF INTERVENTION:</p> <p><input type="checkbox"/> The covering system has been subjected to the yearly extraordinary maintenance.</p> <p><input type="checkbox"/> Further operations carried out:</p> <p>.....</p> <p>.....</p> <p>.....</p> <p>.....</p> <p>.....</p> <p>.....</p> <p>.....</p>	<p>.....</p> <p>.....</p> <p>.....</p> <p>.....</p> <p>.....</p> <p style="text-align: center;">STAMP AND SIGNATURE OF THE AUTHORISED WORKSHOP</p> <p>.....</p>

CARRIED OUT OPERATIONS	REPLACED COMPONENTS
<p>DATE OF INTERVENTION:</p> <p><input type="checkbox"/> The covering system has been subjected to the yearly extraordinary maintenance.</p> <p><input type="checkbox"/> Further operations carried out:</p> <p>.....</p> <p>.....</p> <p>.....</p> <p>.....</p> <p>.....</p> <p>.....</p> <p>.....</p>	<p>.....</p> <p>.....</p> <p>.....</p> <p>.....</p> <p>.....</p> <p style="text-align: center;">STAMP AND SIGNATURE OF THE AUTHORISED WORKSHOP</p> <p>.....</p>

Chapter 6 ENCLOSURES

6.1 Reference diagram for electrical connections

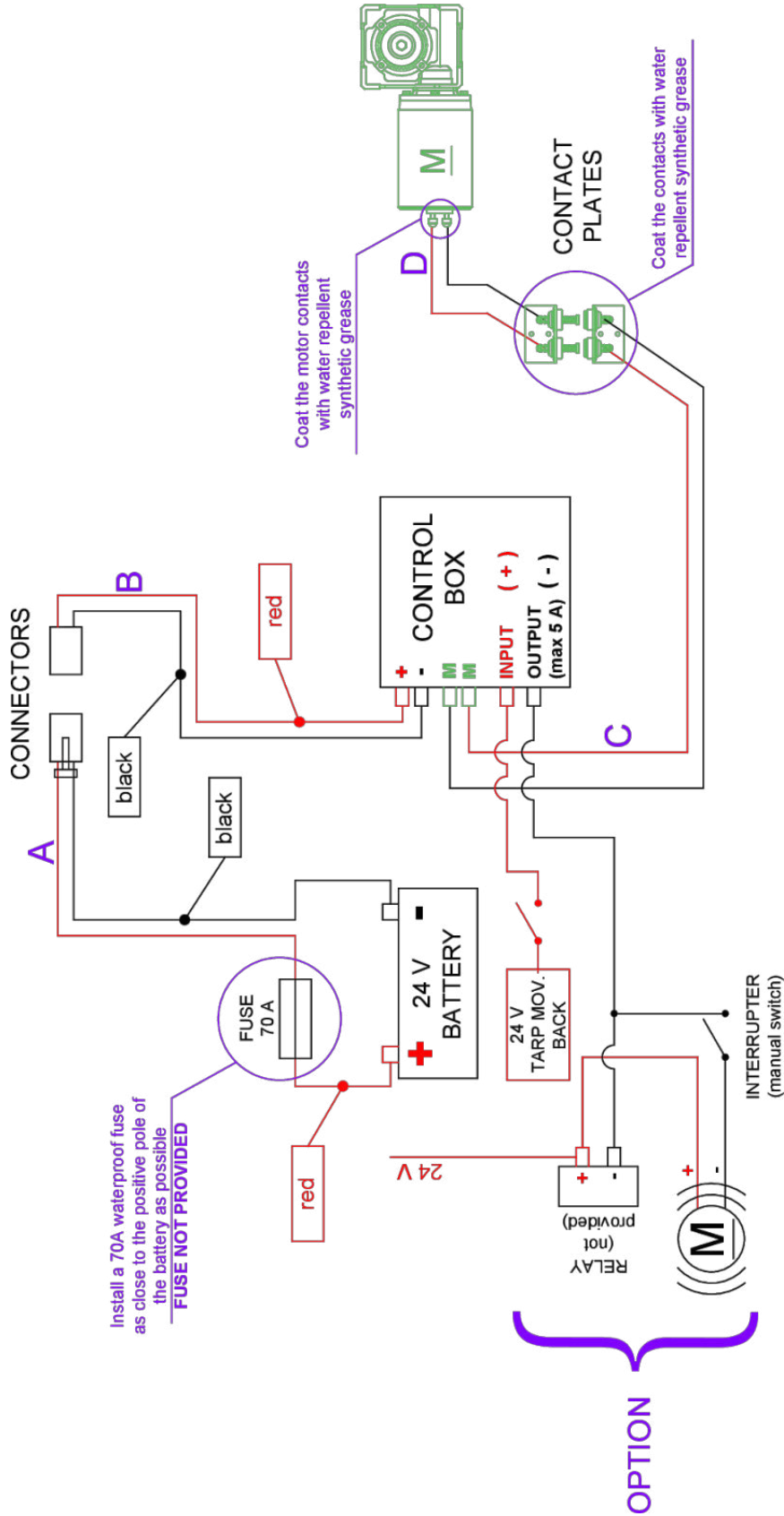

Training course completion declaration

The undersigned Mr.:

resident in: postcode:

address: no.:

phone / mobile: fax / e-mail:

- AS:
- OWNER
 - IN CHARGE OF THE COMPANY INSIDE SAFETY
 - OPERATOR APPOINTED BY THE OWNER
 - USER OF THE MACHINE
 -

DECLARE, UNDER ITS OWN RESPONSIBILITY:

to have attended the training course, to have received and understood the instructions for starting, operating, stopping and keeping in perfect conditions the Covering System by **Marcolin Covering s.r.l.**

Brand / Type: Serial No.:

to have received the manual and to commit himself to understand its contents before using the machine for the first time.

by the manufacturer:



Marcolin Covering s.r.l. – Via Orefici Michelin, 3 – 33170 Pordenone
Tel +39 0434 570261 – www.marcolincovering.it – e-mail info@marcolinsrl.it

COMMIT HIMSELF ALSO TO THE TRAINING COURSE FOR NEW STAFF, IF APPLICABLE, WHO WILL USE THE COVERING SYSTEM FOR ROLL-OFF CONTAINERS AND TIPPER BODIES.

SIGNATURE

MARCOLIN COVERING S.r.l.
Il legale rappresentante

SIGNATURE

Course contractor
(in case of sole owner of the following staff training)

.....

Date:

MARCOLIN COVERING S.R.L. COPY

Training course completion declaration

The undersigned Mr.:

resident in: postcode:

address: no.:

phone / mobile: fax / e-mail:

- AS:
- OWNER
 - IN CHARGE OF THE COMPANY INSIDE SAFETY
 - OPERATOR APPOINTED BY THE OWNER
 - USER OF THE MACHINE
 -

DECLARE, UNDER ITS OWN RESPONSIBILITY:

to have attended the training course, to have received and understood the instructions for starting, operating, stopping and keeping in perfect conditions the Covering System by **Marcolin Covering s.r.l.**

Brand / Type: Serial No.:

to have received the manual and to commit himself to understand its contents before using the machine for the first time.

by the manufacturer:



Marcolin Covering s.r.l. – Via Orefici Michelin, 3 – 33170 Pordenone
Tel +39 0434 570261 – www.marcolincovering.it – e-mail info@marcolinsrl.it

COMMIT HIMSELF ALSO TO THE TRAINING COURSE FOR NEW STAFF, IF APPLICABLE, WHO WILL USE THE COVERING SYSTEM FOR ROLL-OFF CONTAINERS AND TIPPER BODIES.

SIGNATURE

MARCOLIN COVERING S.r.l.
Il legale rappresentante

SIGNATURE

Course contractor
(in case of sole owner of the following staff training)

.....

Date:

RETAILER COPY

Training course completion declaration

The undersigned Mr.:

resident in: postcode:

address: no.:

phone / mobile: fax / e-mail:

- AS:
- OWNER
 - IN CHARGE OF THE COMPANY INSIDE SAFETY
 - OPERATOR APPOINTED BY THE OWNER
 - USER OF THE MACHINE
 -

DECLARE, UNDER ITS OWN RESPONSIBILITY:

to have attended the training course, to have received and understood the instructions for starting, operating, stopping and keeping in perfect conditions the Covering System by **Marcolin Covering s.r.l.**

Brand / Type: Serial No.:

to have received the manual and to commit himself to understand its contents before using the machine for the first time.

by the manufacturer:



Marcolin Covering s.r.l. – Via Orefici Michelin, 3 – 33170 Pordenone
Tel +39 0434 570261 – www.marcolincovering.it – e-mail info@marcolinsrl.it

COMMIT HIMSELF ALSO TO THE TRAINING COURSE FOR NEW STAFF, IF APPLICABLE, WHO WILL USE THE COVERING SYSTEM FOR ROLL-OFF CONTAINERS AND TIPPER BODIES.

SIGNATURE

MARCOLIN COVERING S.r.l.
Il legale rappresentante

SIGNATURE

Course contractor
(in case of sole owner of the following staff training)

.....

Date:

CUSTOMER COPY

Declaration of training course completion for new users

TRAINING COURSE MADE ON (DATE):.....

The undersigned Mr.:

resident in: postcode:

address: no.:

phone / mobile: fax / e-mail:

DECLARE, UNDER ITS OWN RESPONSIBILITY:

- to have attended the training course, to have received and understood the instructions for starting, operating, stopping and keeping in perfect working conditions the Covering System by Marcolin Covering s.r.l.

Brand / Type: Serial No.:

- to have received the manual and to commit himself to understand its contents before using the machine for the first time.;

by Mr.:

resident in: postcode:

address: no.:

phone / mobile: fax / e-mail:

COMMIT HIMSELF ALSO TO INFORMING AND TRAINING THE NEW COLLEAGUES WHO WILL USE THE MACHINE

SIGNATURE

Responsible for the implementation of the training course

SIGNATURE

Receiver of the training course

.....

.....

TRAINING COURSE MADE ON (DATE):.....

The undersigned Mr.:

resident in: postcode:

address: no.:

phone / mobile: fax / e-mail:

DECLARE, UNDER ITS OWN RESPONSIBILITY:

- to have attended the training course, to have received and understood the instructions for starting, operating, stopping and keeping in perfect working conditions the Covering System by Marcolin Covering s.r.l.

Brand / Type: Serial No.:

- to have received the manual and to commit himself to understand its contents before using the machine for the first time.;

by Mr.:

resident in: postcode:

address: no.:

phone / mobile: fax / e-mail:

COMMIT HIMSELF ALSO TO INFORMING AND TRAINING THE NEW COLLEAGUES WHO WILL USE THE MACHINE

SIGNATURE

Responsible for the implementation of the training course

SIGNATURE

Receiver of the training course

.....

.....

i Before using this last printout, please make some photocopies and insert them in the manual.

TRAINING COURSE MADE ON (DATE):

The undersigned Mr.:

resident in: postcode:

address: no.:

phone / mobile: fax / e-mail:

DECLARE, UNDER ITS OWN RESPONSIBILITY:

to have attended the training course, to have received and understood the instructions for starting, operating, stopping and keeping in perfect working conditions the Covering System by Marcolin Covering s.r.l.

Brand / Type: Serial No.:

to have received the manual and to commit himself to understand its contents before using the machine for the first time.;

by Mr.:

resident in: postcode:

address: no.:

phone / mobile: fax / e-mail:

**COMMIT HIMSELF ALSO TO INFORMING AND TRAINING
THE NEW COLLEAGUES WHO WILL USE THE MACHINE**

SIGNATURE

Responsible for the implementation of the training course

.....

SIGNATURE

Receiver of the training course

.....

TRAINING COURSE MADE ON (DATE):

The undersigned Mr.:

resident in: postcode:

address: no.:

phone / mobile: fax / e-mail:

DECLARE, UNDER ITS OWN RESPONSIBILITY:

to have attended the training course, to have received and understood the instructions for starting, operating, stopping and keeping in perfect working conditions the Covering System by Marcolin Covering s.r.l.

Brand / Type: Serial No.:

to have received the manual and to commit himself to understand its contents before using the machine for the first time.;

by Mr.:

resident in: postcode:

address: no.:

phone / mobile: fax / e-mail:

**COMMIT HIMSELF ALSO TO INFORMING AND TRAINING
THE NEW COLLEAGUES WHO WILL USE THE MACHINE**

SIGNATURE

Responsible for the implementation of the training course

.....

SIGNATURE

Receiver of the training course

.....

Declaration of training course completion for owners

TRAINING COURSE TO THE OWNERS MADE ON (DATE):

The undersigned Mr.:

resident in: postcode:

address: no.:

phone / mobile: fax / e-mail:

DECLARE, UNDER ITS OWN RESPONSIBILITY:

- to have attended the training course, to have received and understood the instructions for starting, operating, stopping and keeping in perfect working conditions the Covering System by Marcolin Covering s.r.l.

Brand / Type: Serial No.:

- to have received the original EC Declaration of Conformity, this manual and to commit himself to understand the contents before using the machine for the first time;

by Mr.:

resident in: postcode:

address: no.:

phone / mobile: fax / e-mail:

**COMMIT HIMSELF ALSO TO INFORMING AND TRAINING
HIS EMPLOYEES AND THE NEW PURCHASERS, IF ANY**

SIGNATURE

Responsible for the implementation of the training course

.....

SIGNATURE

Receiver of the training course

.....

TRAINING COURSE TO THE OWNERS MADE ON:

The undersigned Mr.:

resident in: postcode:

address: no.:

phone / mobile: fax / e-mail:

DECLARE, UNDER ITS OWN RESPONSIBILITY:

- to have attended the training course, to have received and understood the instructions for starting, operating, stopping and keeping in perfect working conditions the Covering System by Marcolin Covering s.r.l.

Brand / Type: Serial No.:

- to have received the original EC Declaration of Conformity, this manual and to commit himself to understand the contents before using the machine for the first time;

by Mr.:

resident in: postcode:

address: no.:

phone / mobile: fax / e-mail:

**COMMIT HIMSELF ALSO TO INFORMING AND TRAINING
HIS EMPLOYEES AND THE NEW PURCHASERS, IF ANY**

SIGNATURE

Responsible for the implementation of the training course

.....

SIGNATURE

Receiver of the training course

.....

marcolin
the covering evolution

Marcolin Covering Srl
Via O. Michelin, 3 / 33170 Pordenone - Italy / T +39 0434 570261 / info@marcolinsrl.it
marcolincovering.it